

10. Schematic Diagram

10-1 Main Board

10-1-1 Main-1

This Document can not be used without Samsung's authorization.

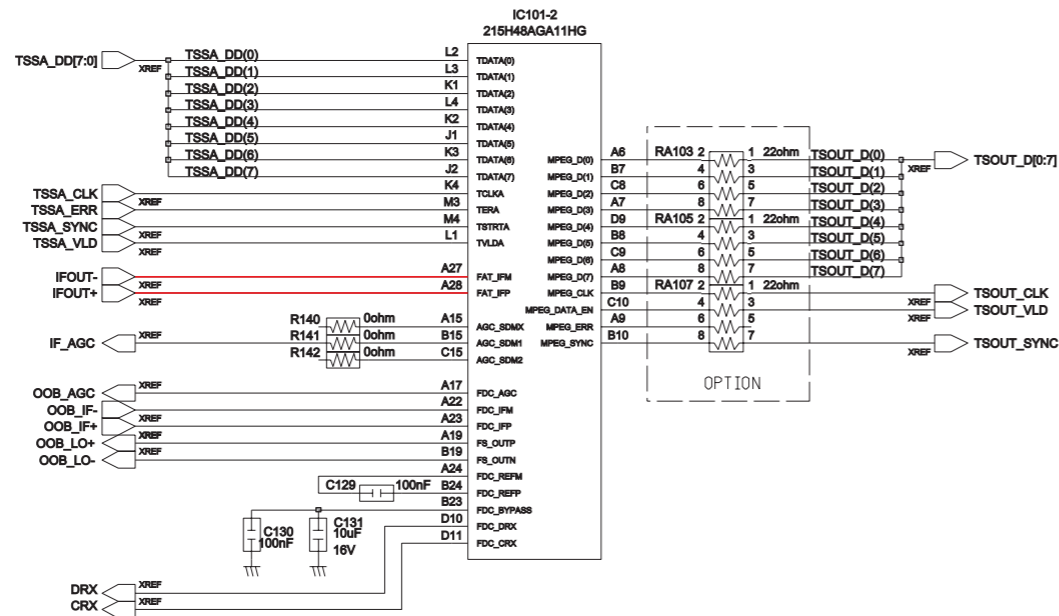
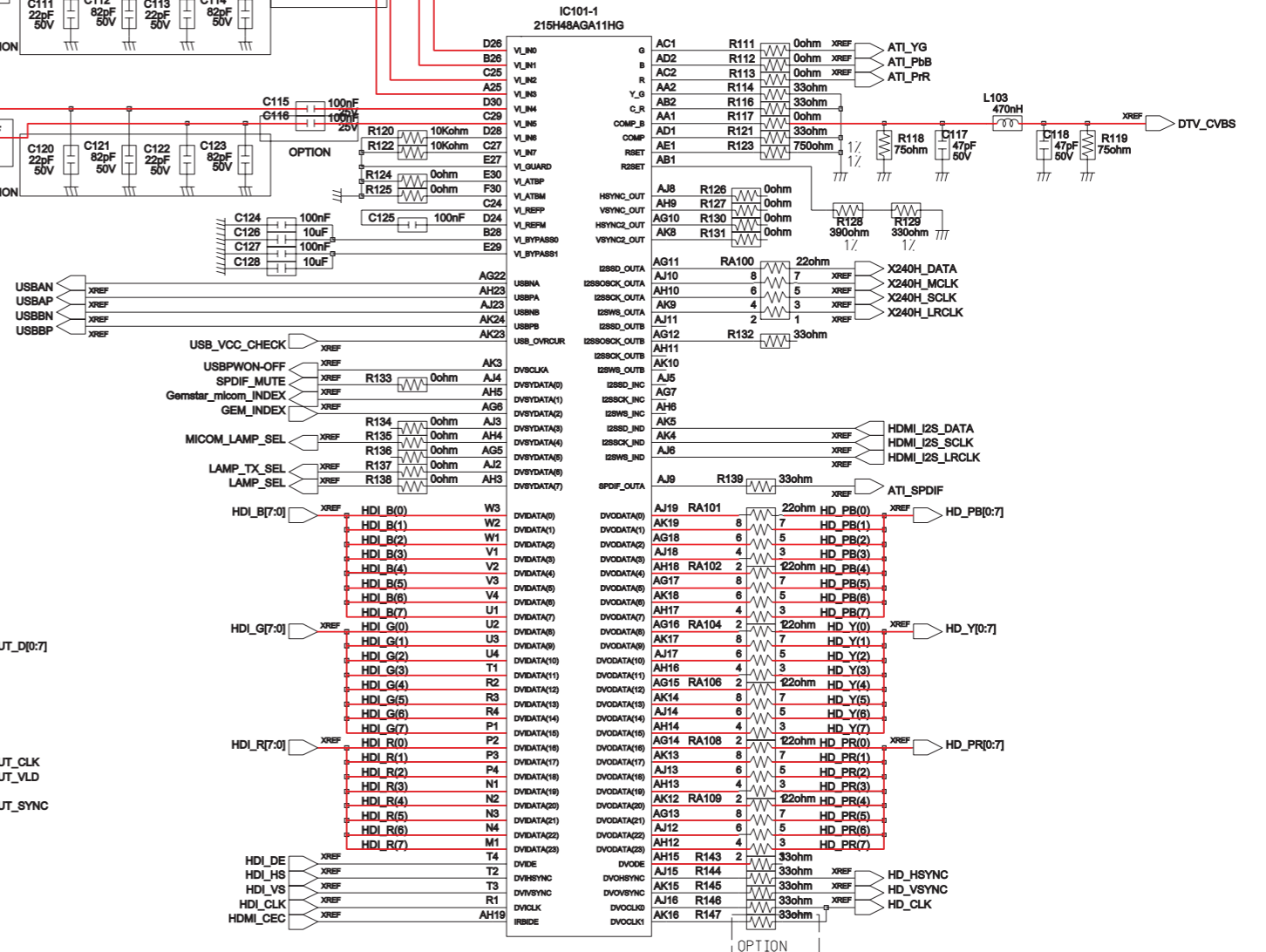
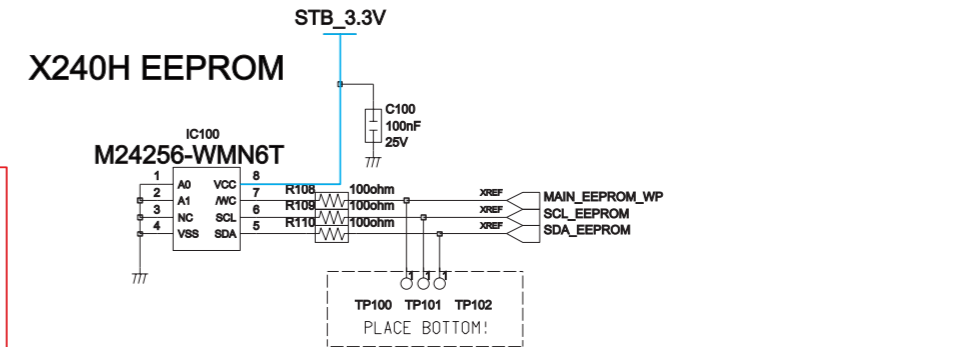
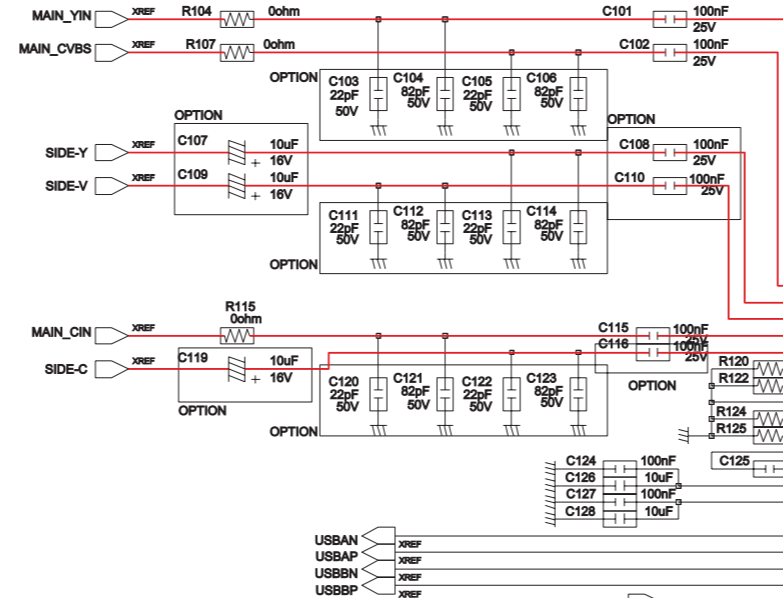
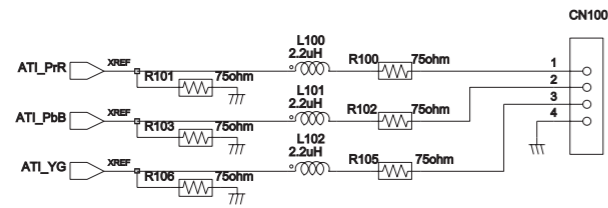
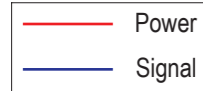

10-1-2 Main-2

This Document can not be used without Samsung's authorization.

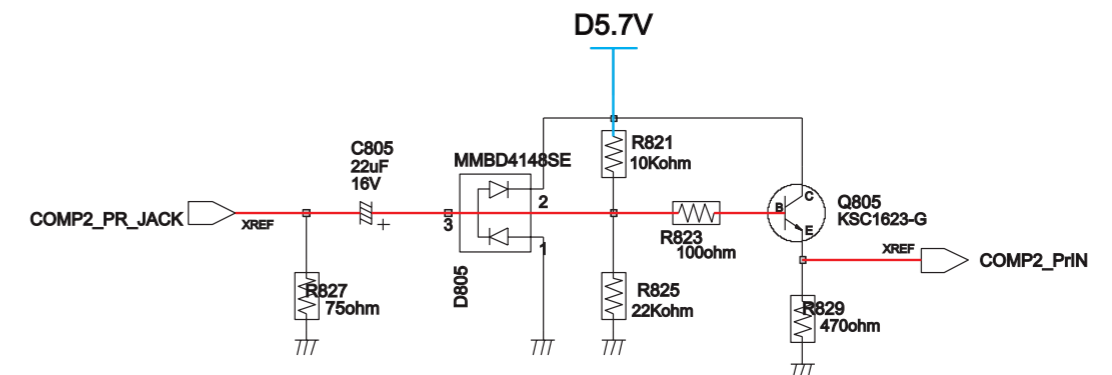
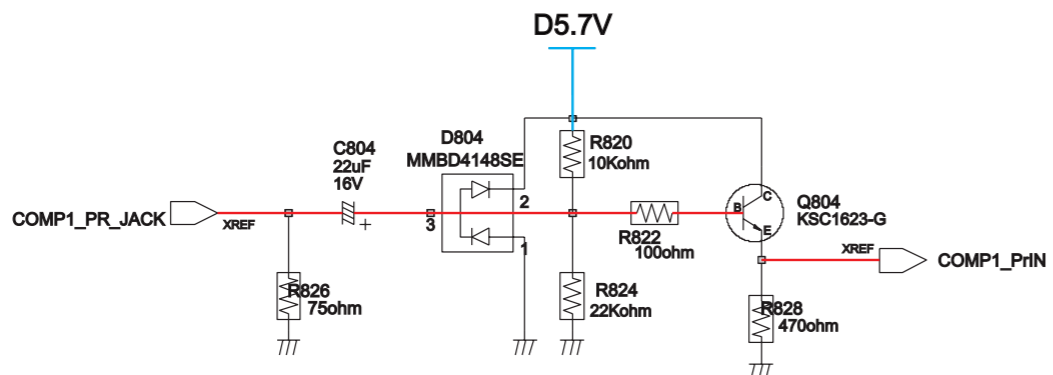
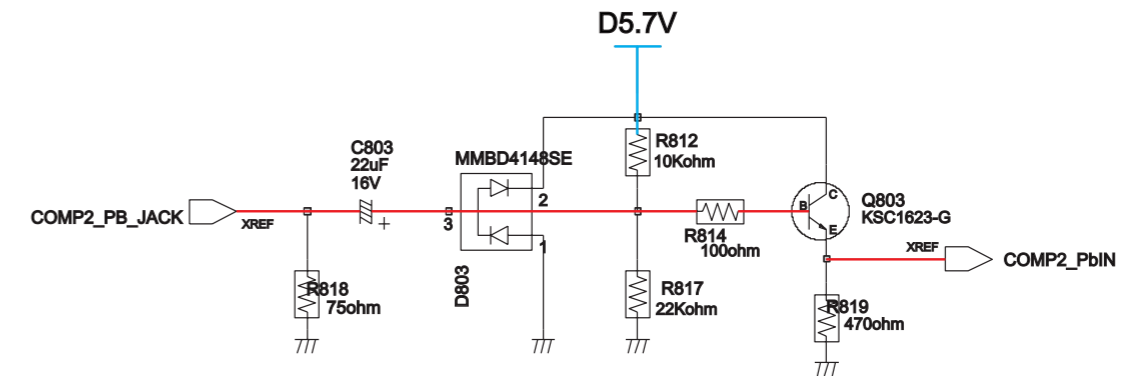
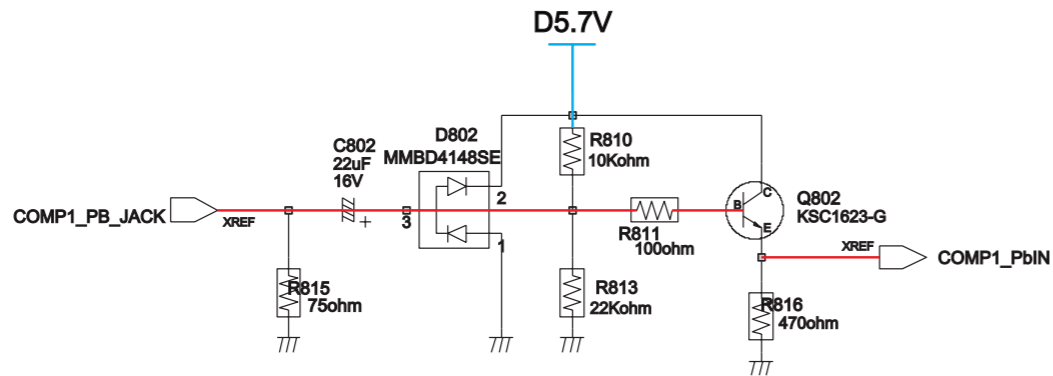
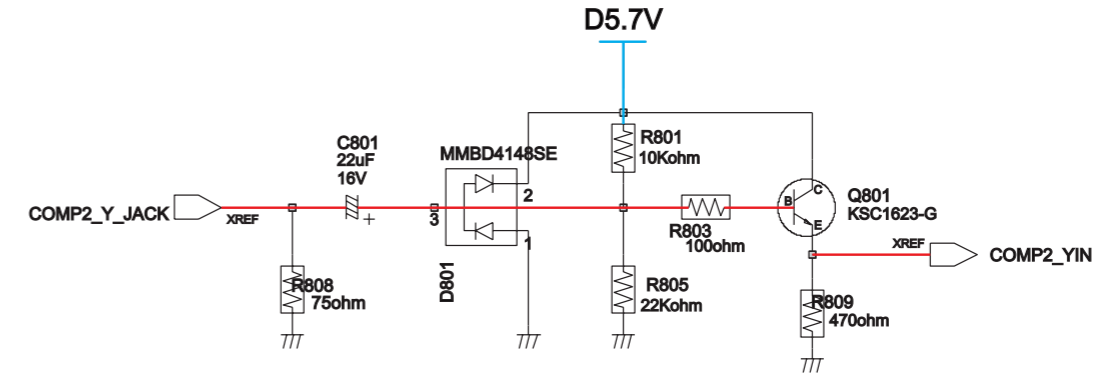
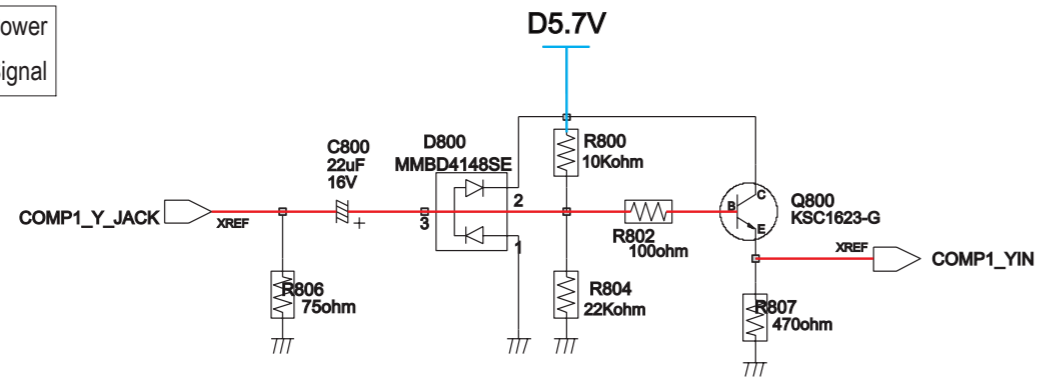

10-1-3 Main-3

This Document can not be used without Samsung's authorization.

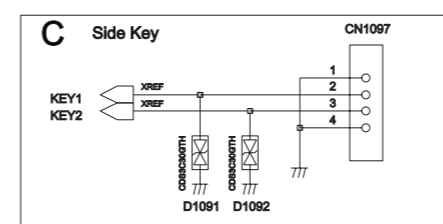
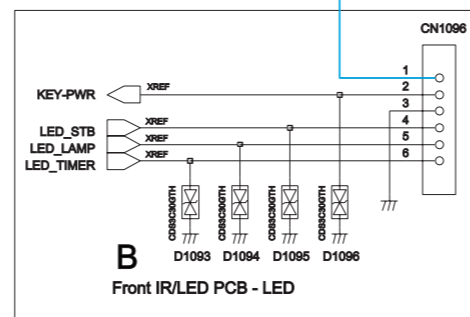
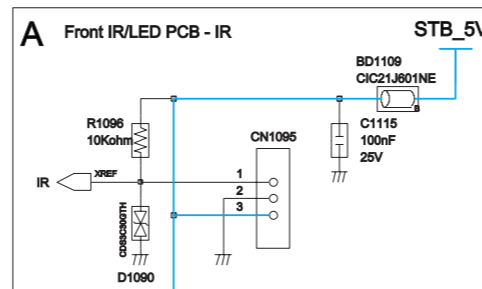
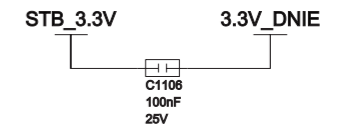
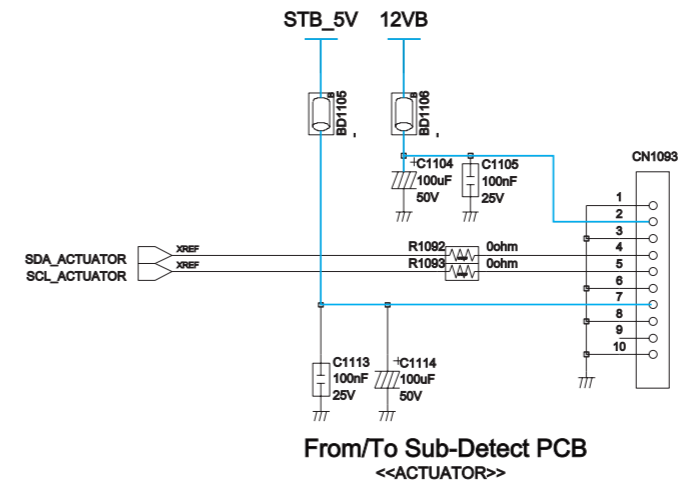
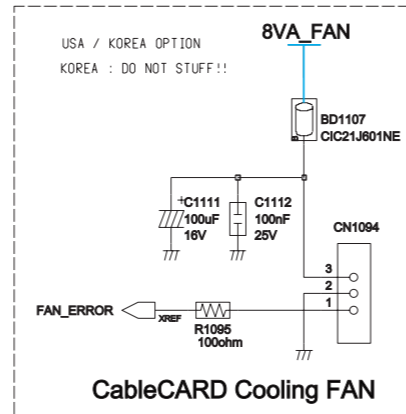
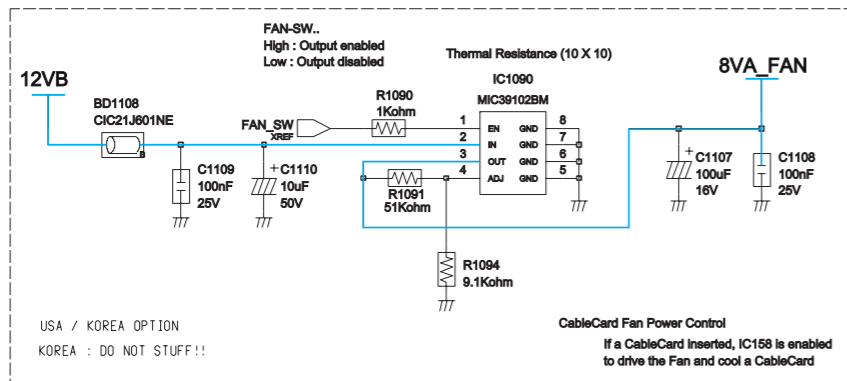
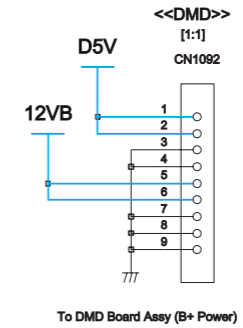
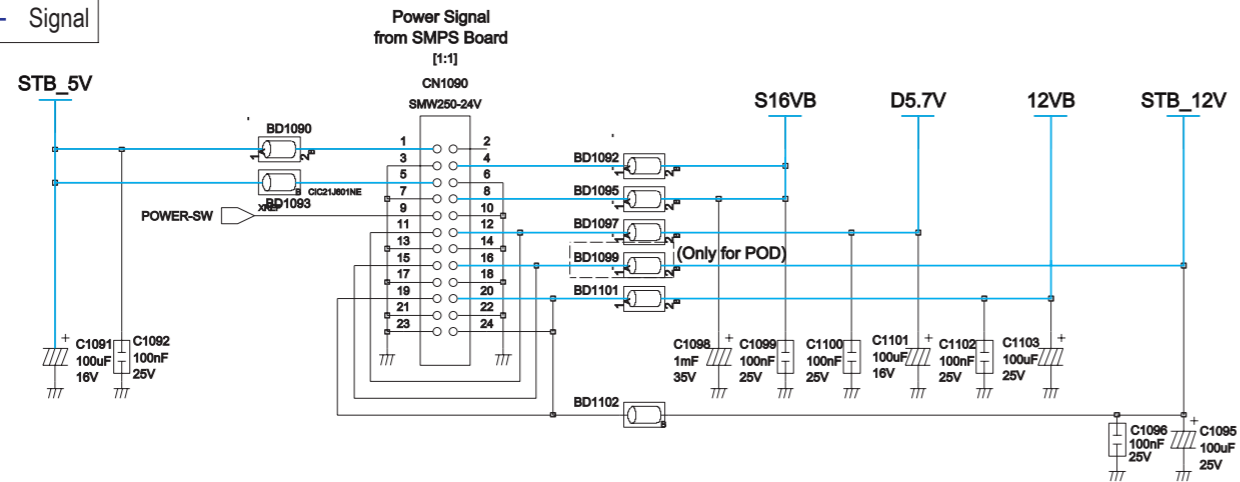
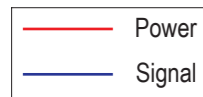

A	B	C	D
1. IR	1. 5VA	1. GND	1. LED1
2. GND	2. KEY-PWR	2. KEY1	2. KEY1
3. 5VA	3. GND	3. KEY2	3. KEY2
	4. LED1	4. GND	4. SDA-M1
	5. LED2		5. SCL-M1
	6. LED3		6. 5VB
			7. GND

Used as follows...
L3 : A+B, C
L5 : A, B, C
L7 : A, D

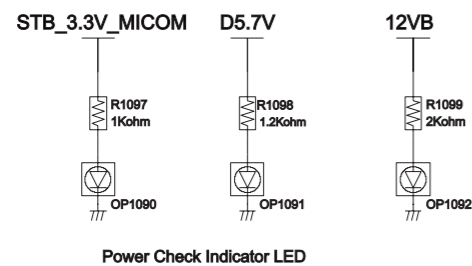

10-1-4 Main-4

This Document can not be used without Samsung's authorization.

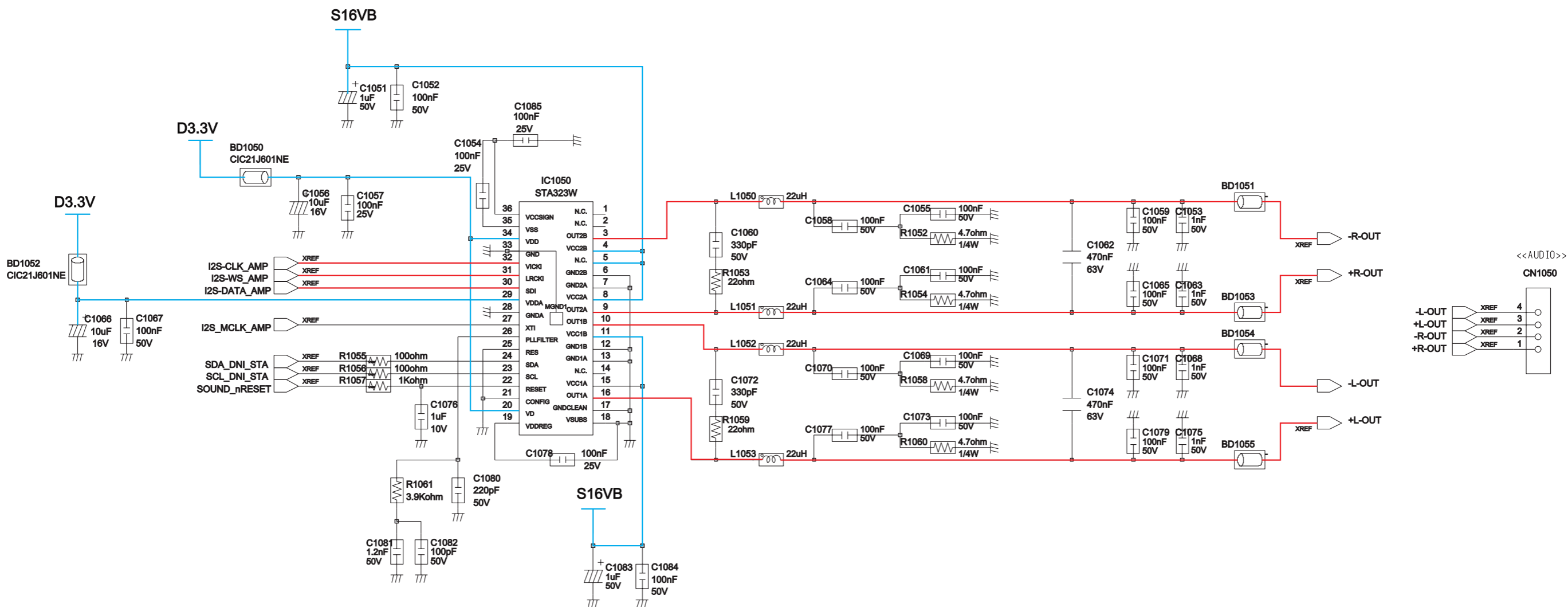
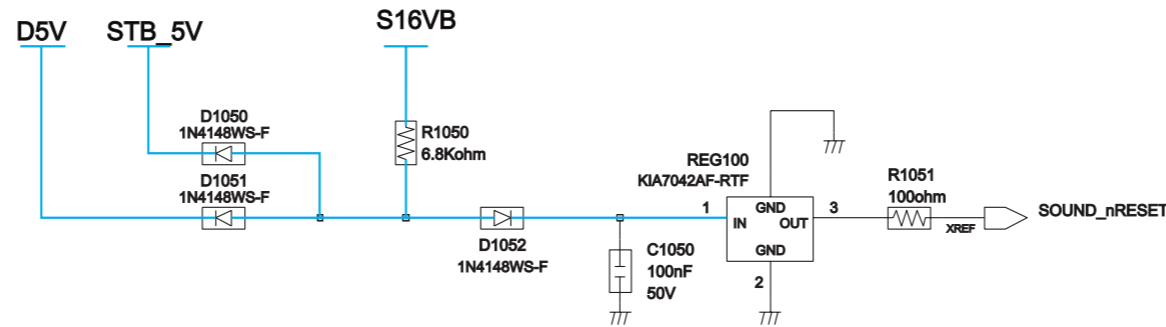
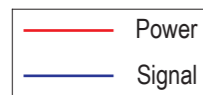

10-1-5 Main-5

This Document can not be used without Samsung's authorization.

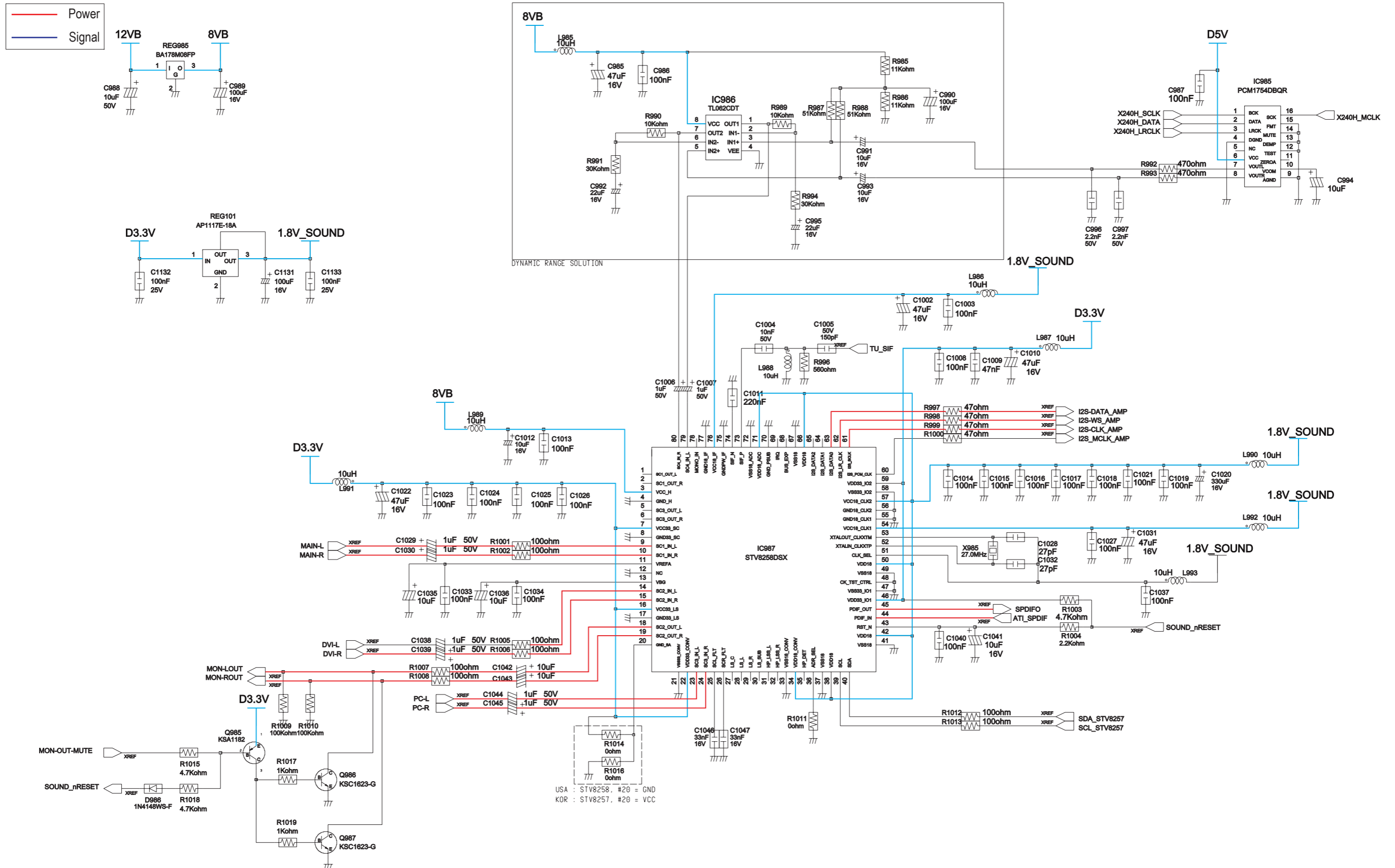

10-1-6 Main-6

This Document can not be used without Samsung's authorization.

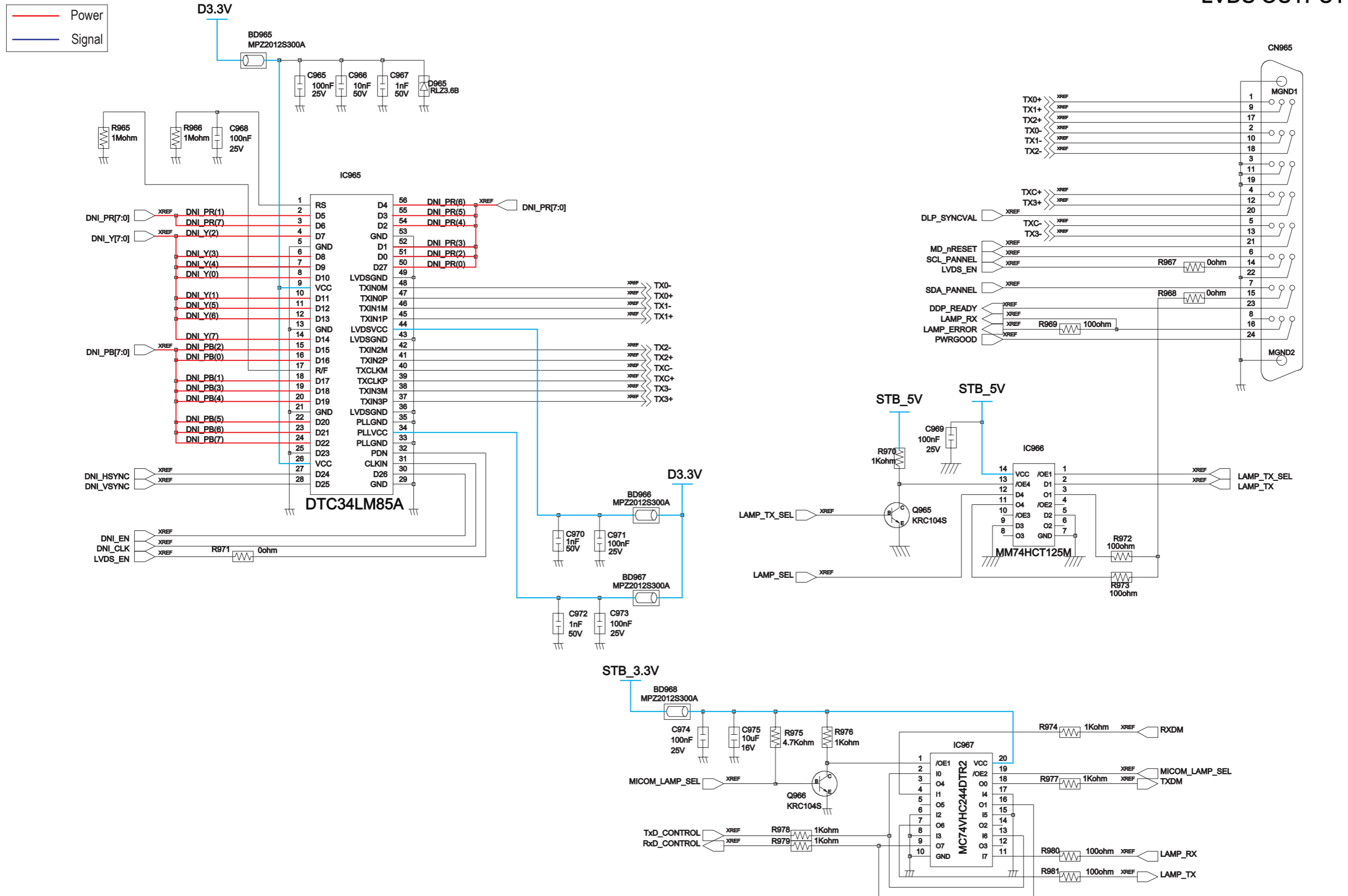

10-1-7 Main-7

This Document can not be used without Samsung's authorization.

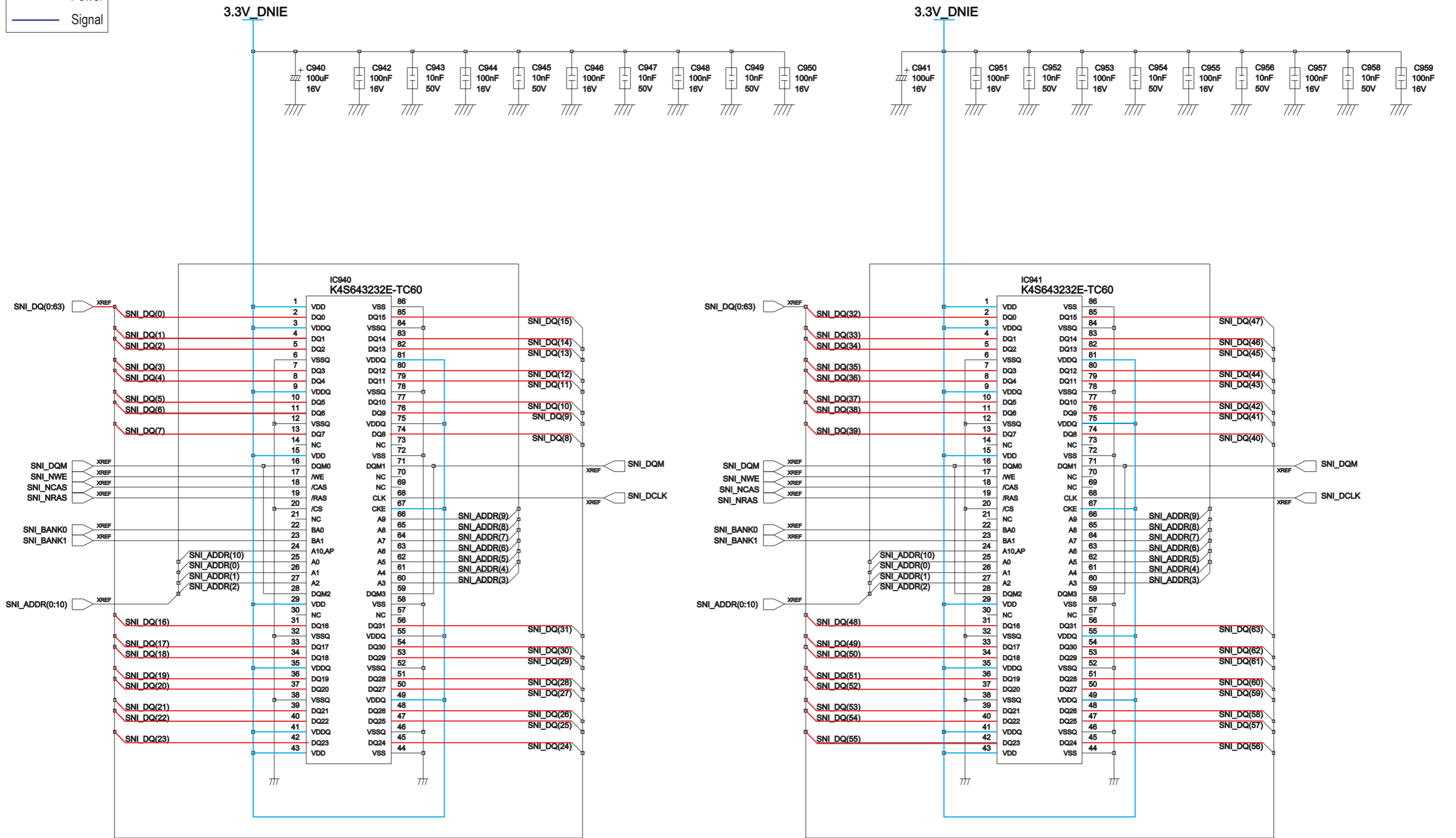
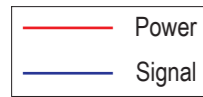

10-1-8 Main-8

This Document can not be used without Samsung's authorization.

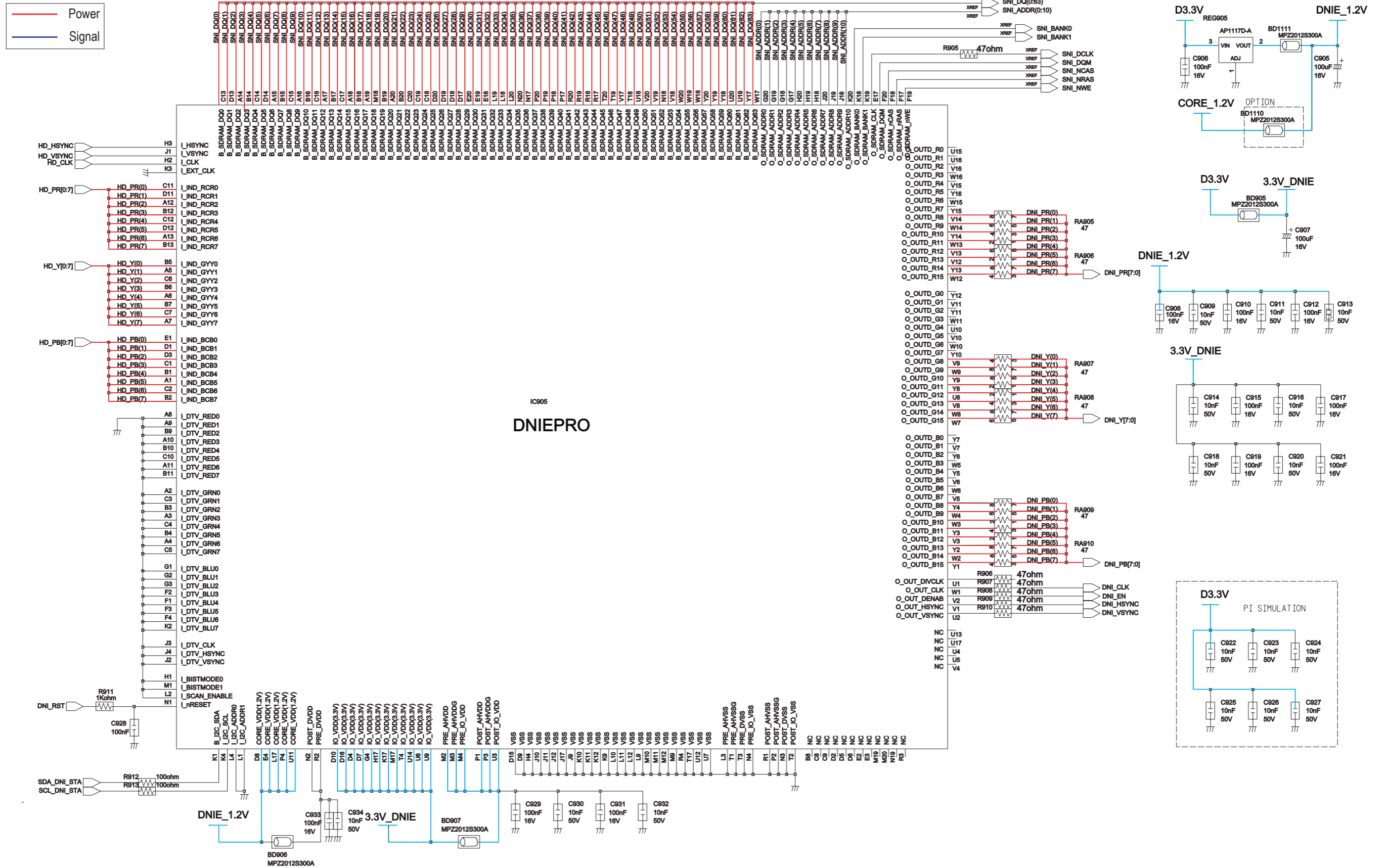

10-1-9 Main-9

This Document can not be used without Samsung's authorization.

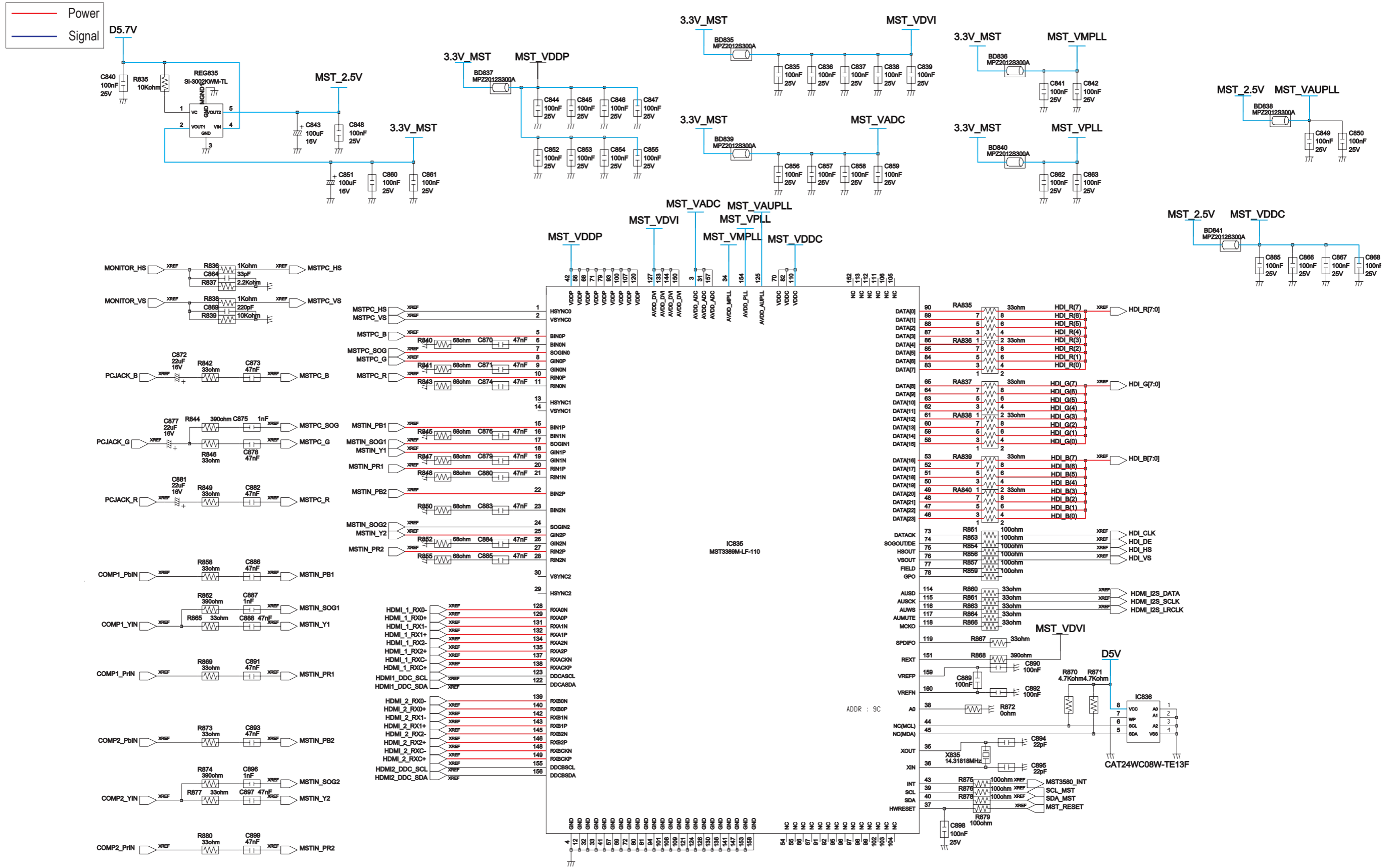

10-1-10 Main-10

This Document can not be used without Samsung's authorization.

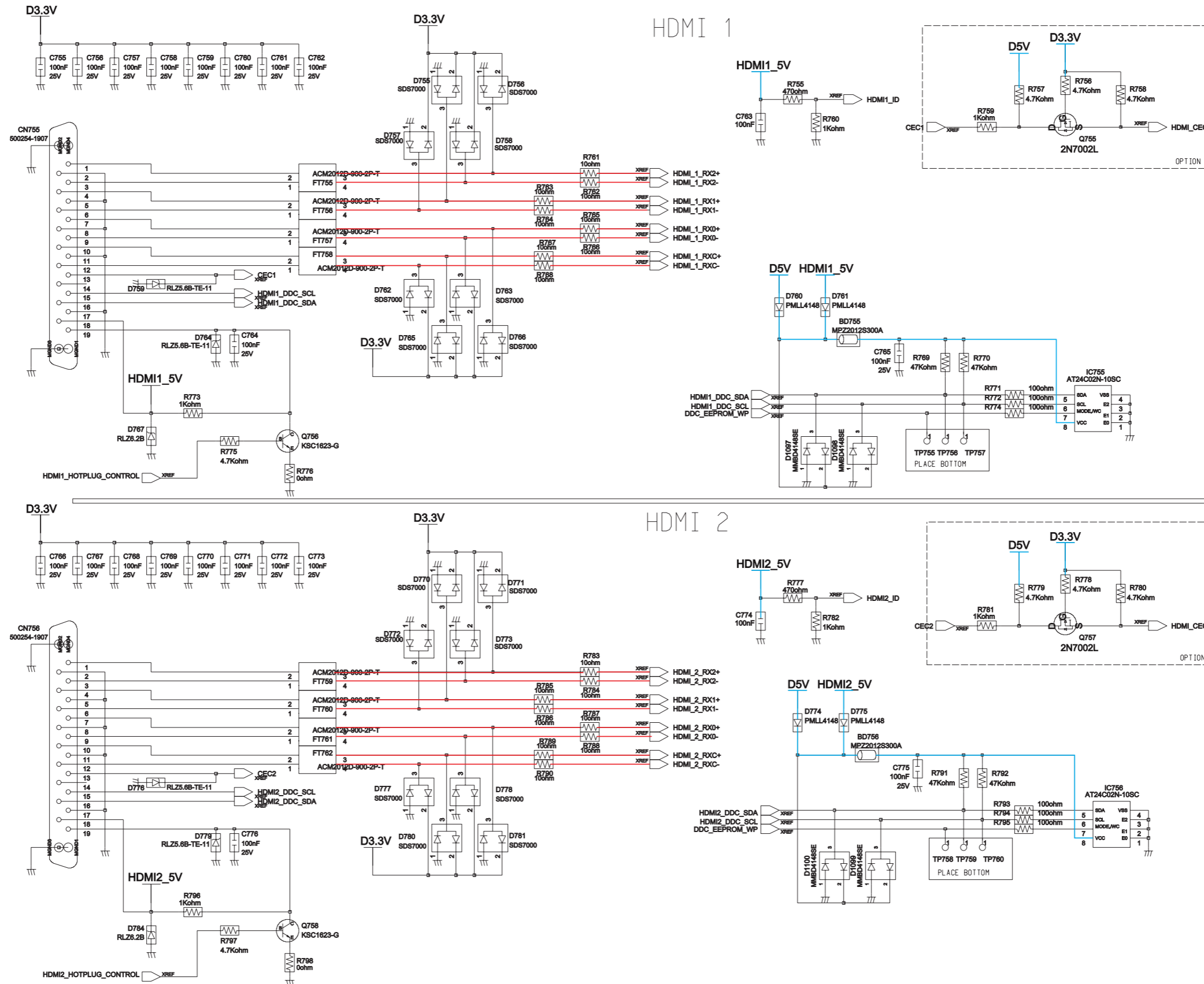
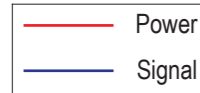

10-1-11 Main-11

This Document can not be used without Samsung's authorization.

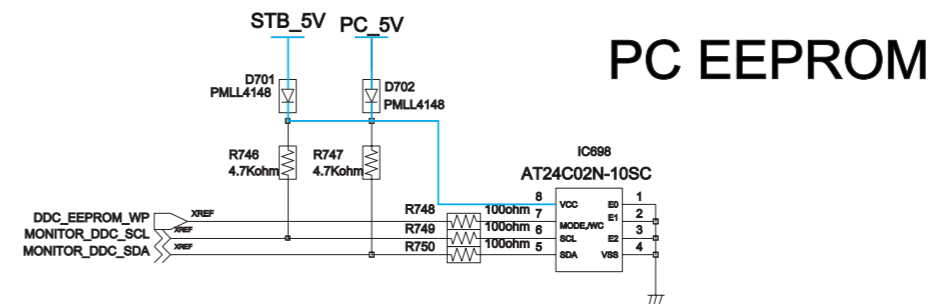
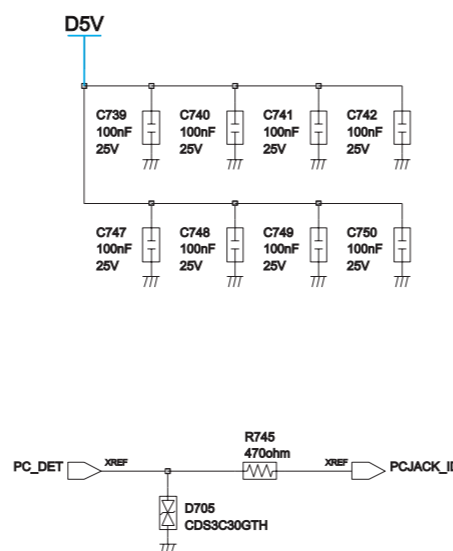
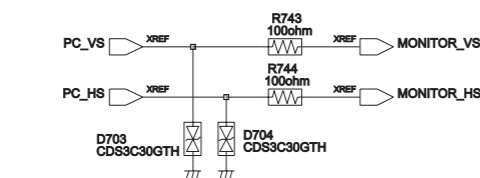
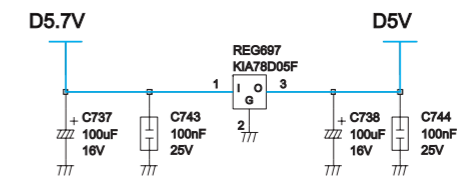
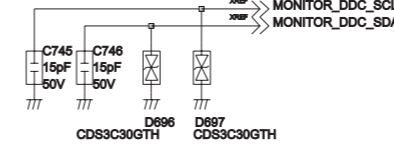
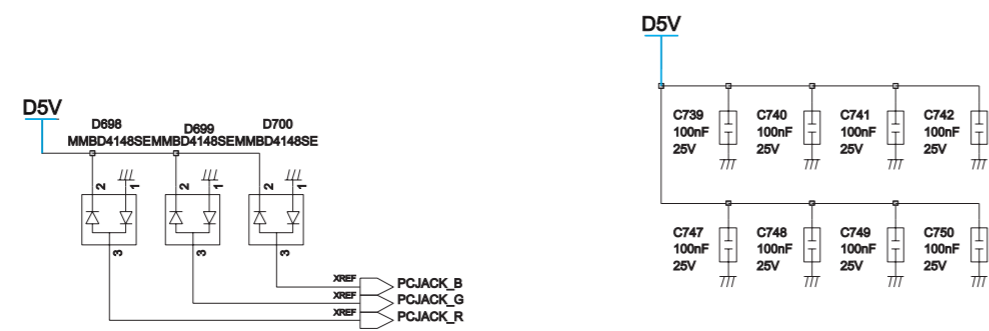
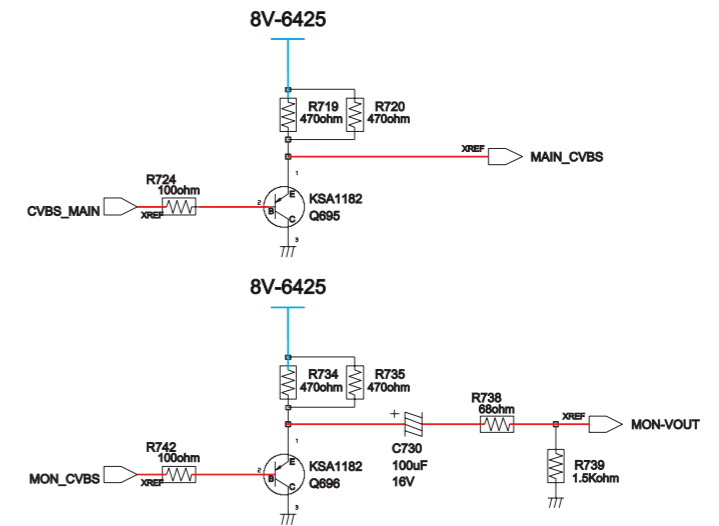
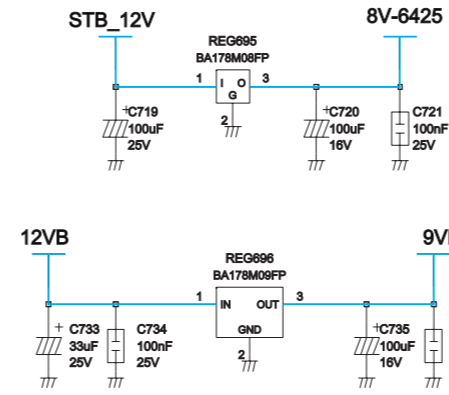
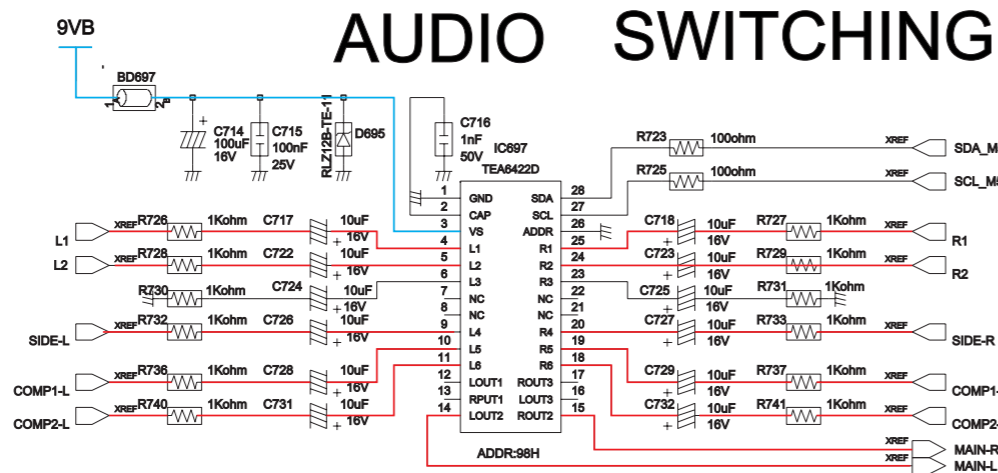
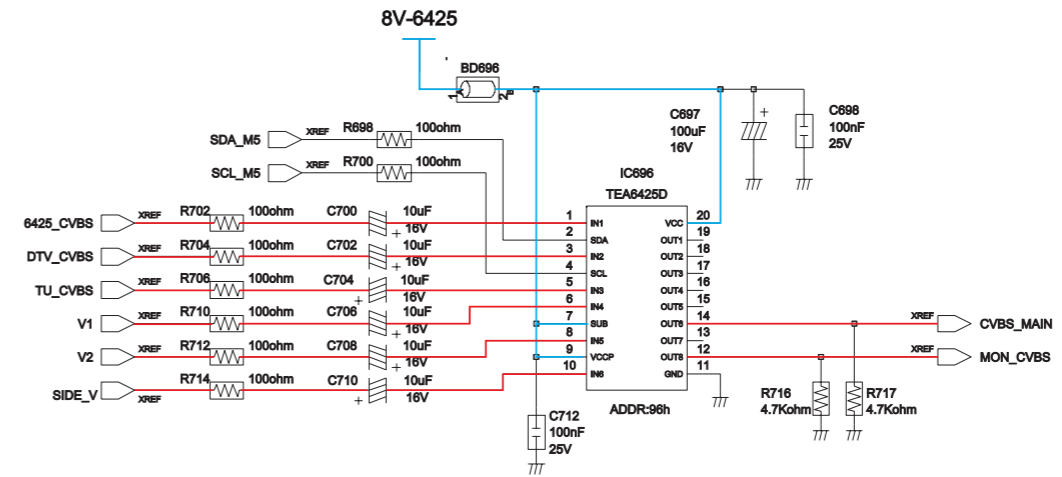
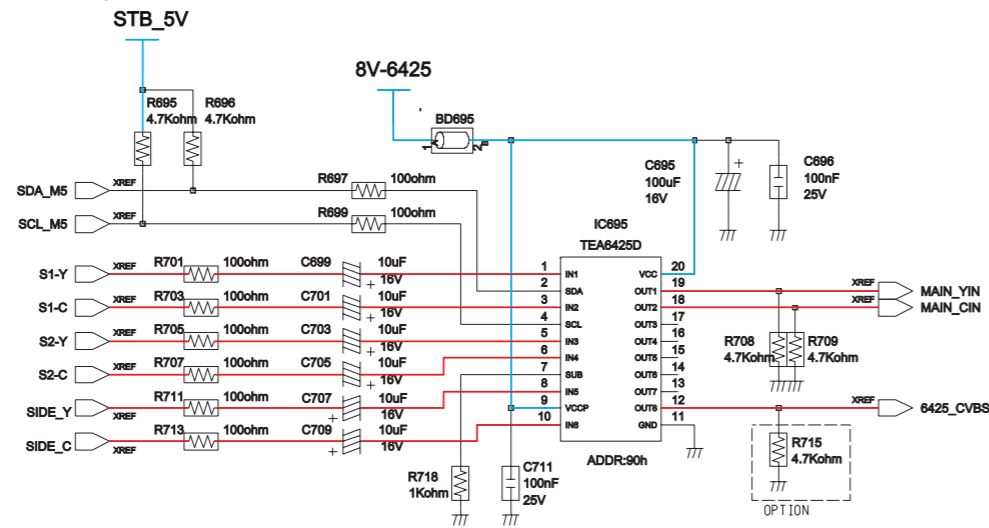
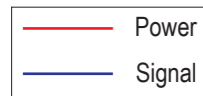

10-1-12 Main-12

This Document can not be used without Samsung's authorization.

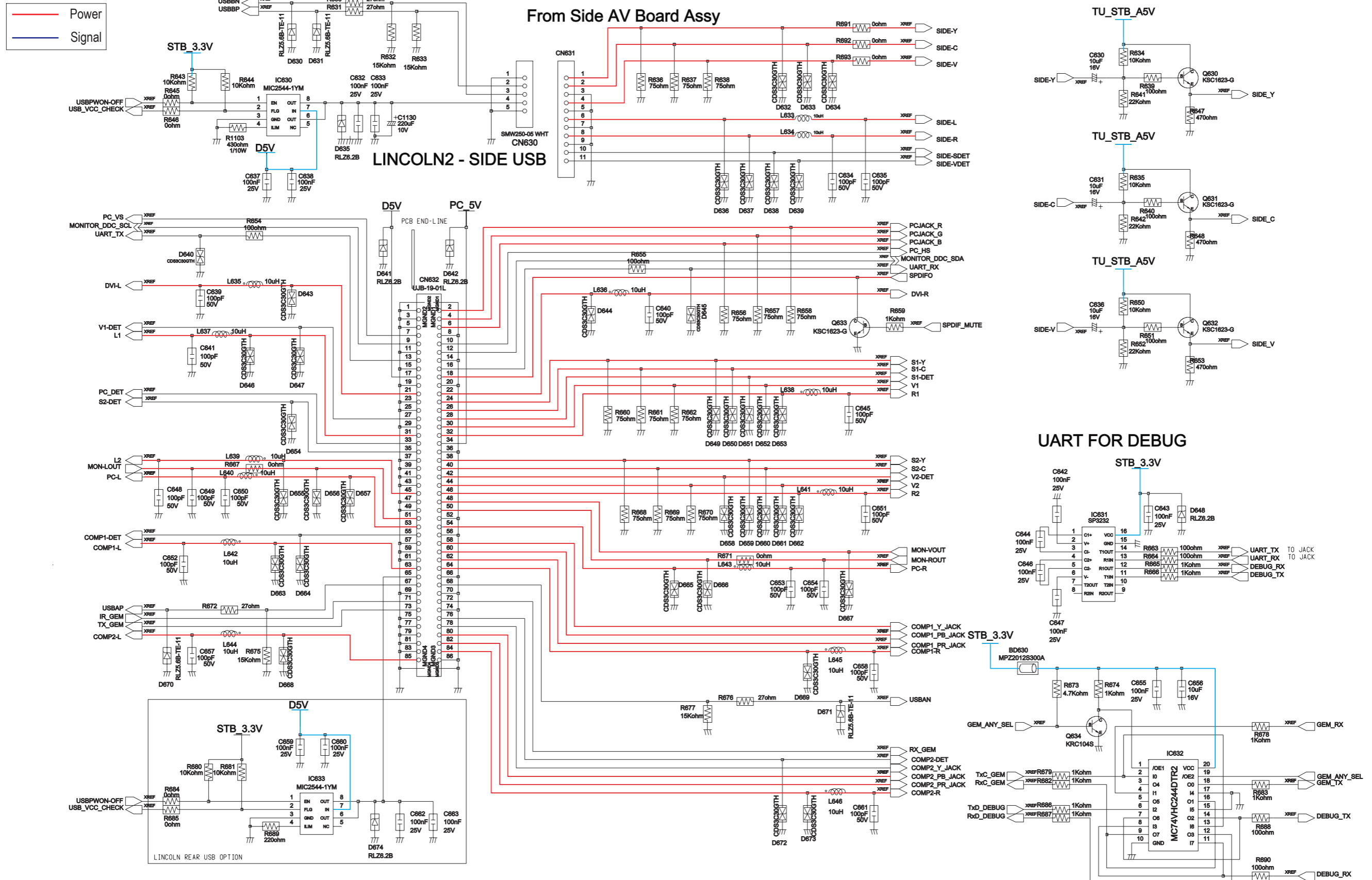

10-1-13 Main-13

This Document can not be used without Samsung's authorization.

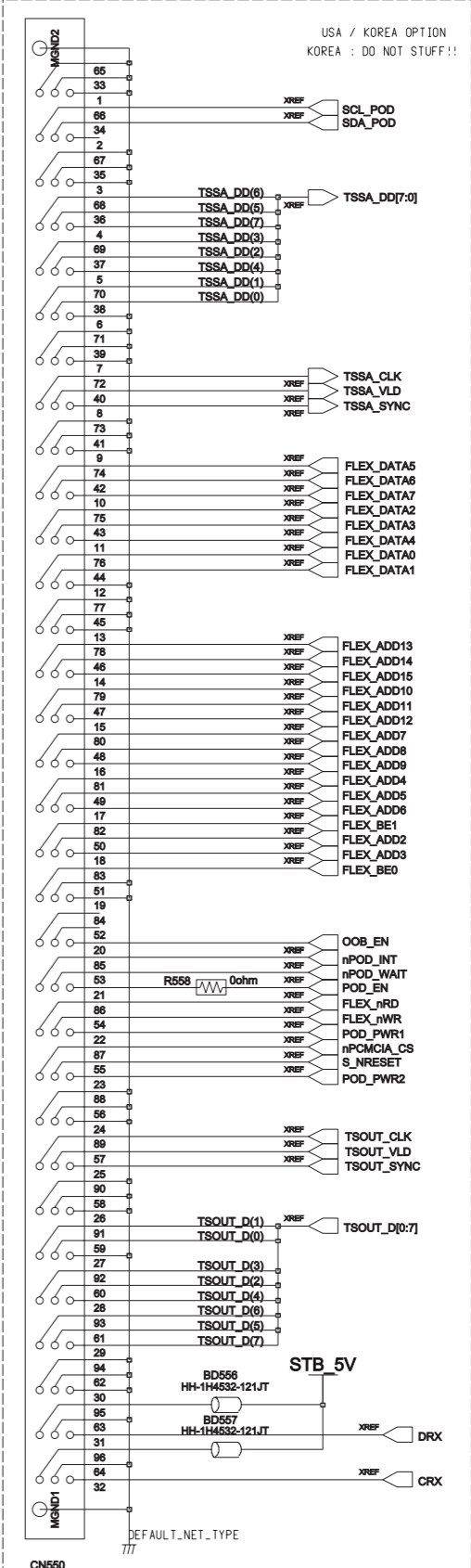
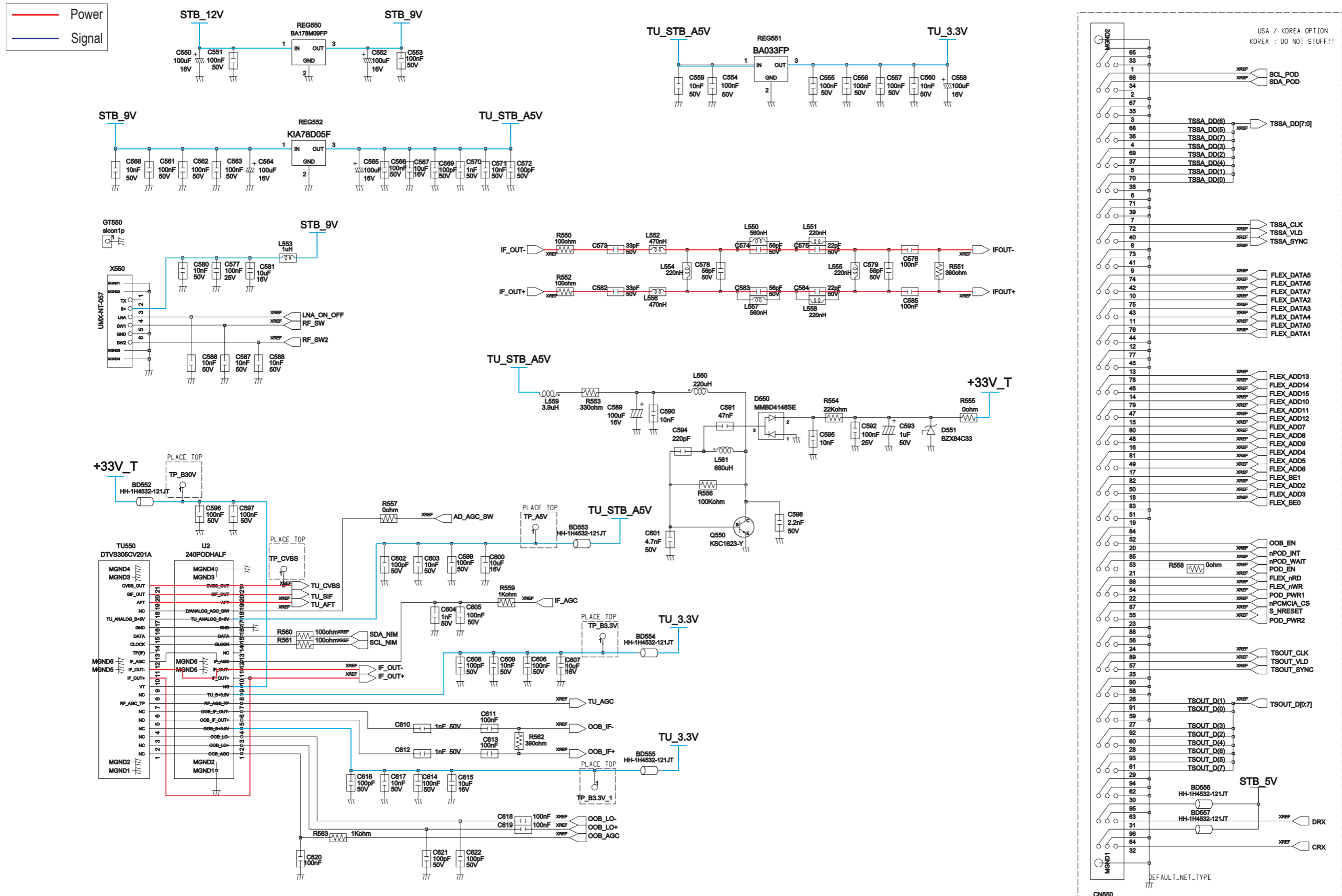

10-1-14 Main-14

This Document can not be used without Samsung's authorization.

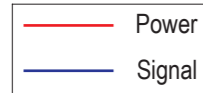

FOR GEMSTAR APPLCIATOIN

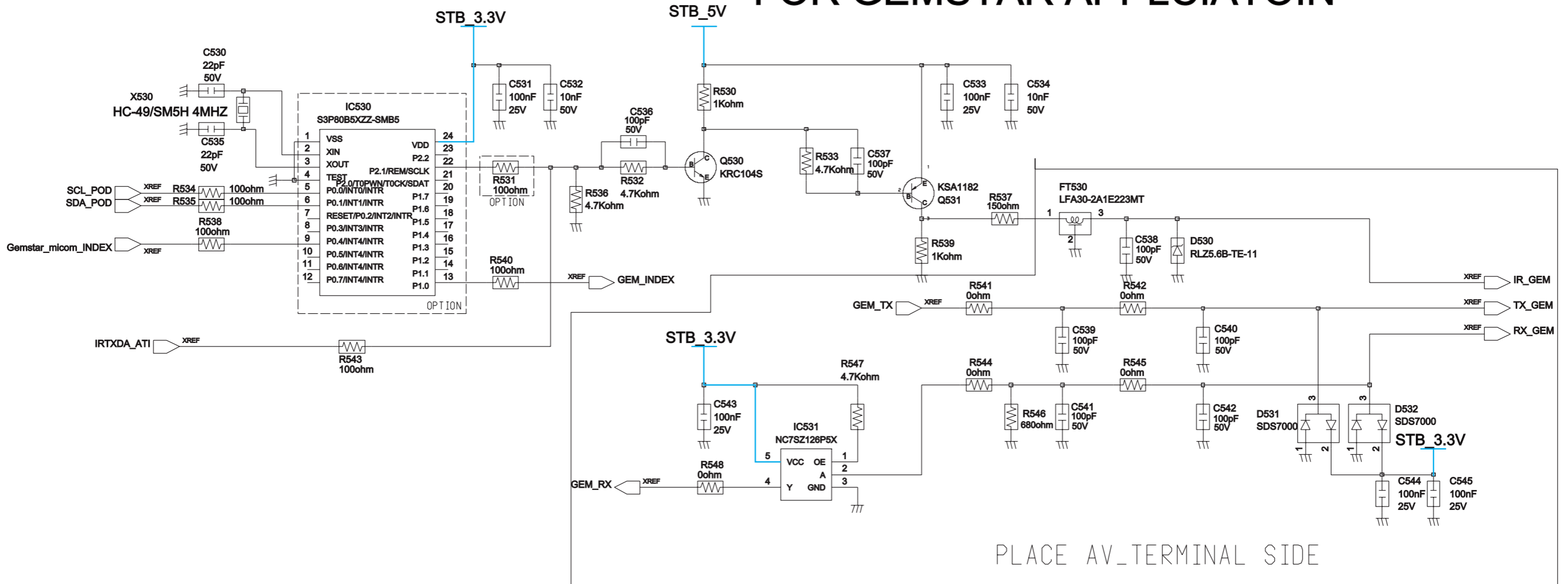

10-1-15 Main-15

This Document can not be used without Samsung's authorization.

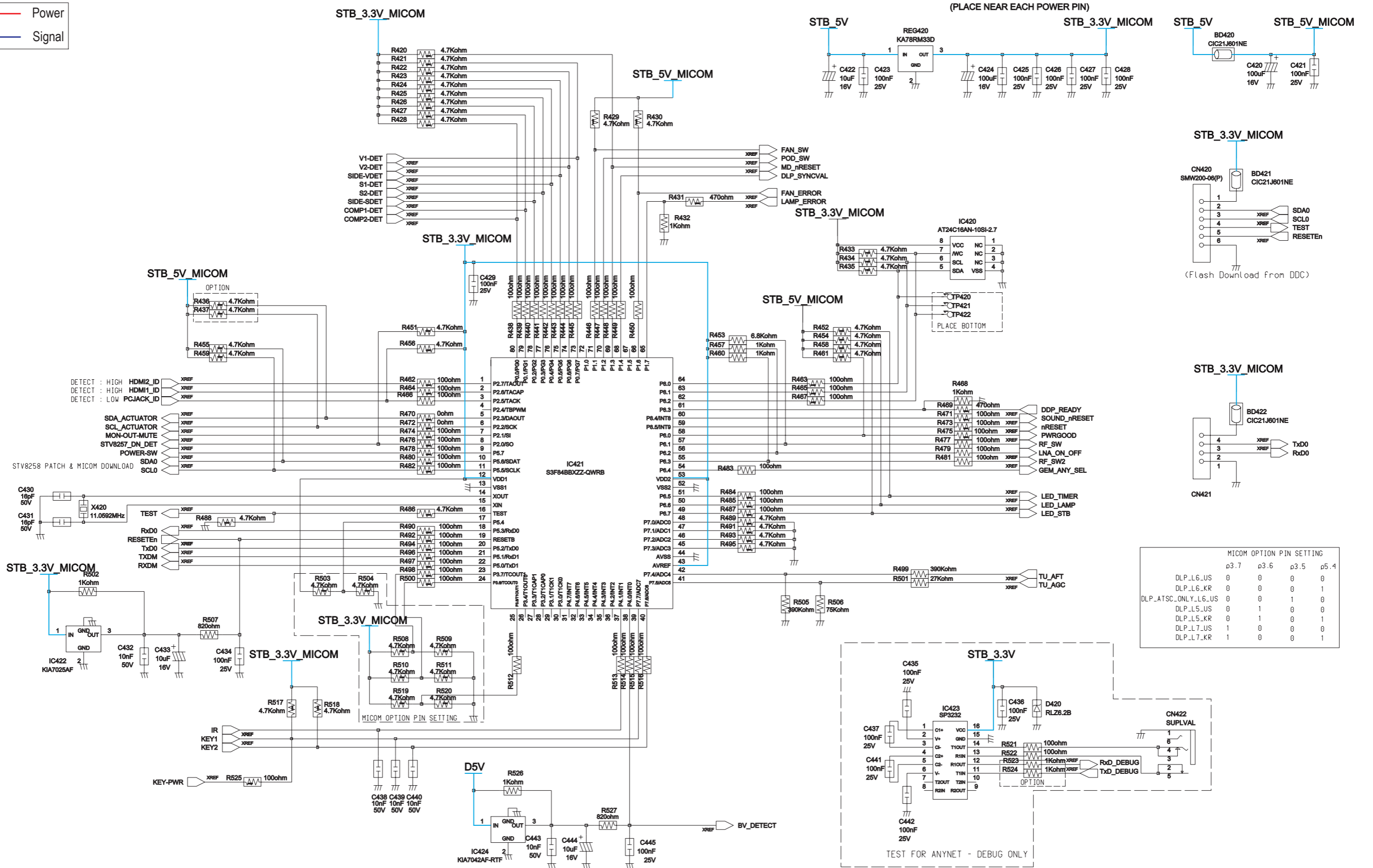

MICOM OPTION PIN SETTING

	ρ3.7	ρ3.6	ρ3.5	ρ5.4
DLP_L6_US	0	0	0	0
DLP_L6_KR	0	0	0	1
DLP_ATSC_ONLY_L6_US	0	0	1	0
DLP_L5_US	0	1	0	0
DLP_L5_KR	0	1	0	1
DLP_L7_US	1	0	0	0
DLP_L7_KR	1	0	0	1

10-1-16 Main-16

This Document can not be used without Samsung's authorization.

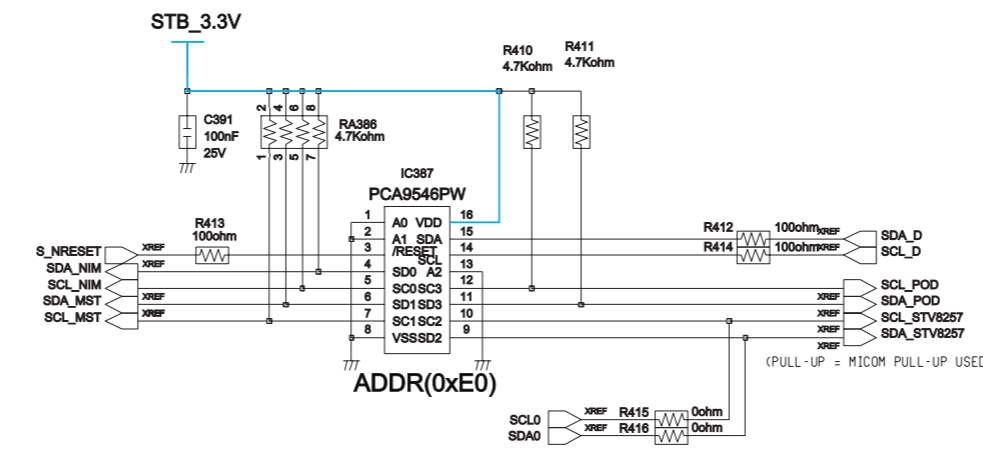
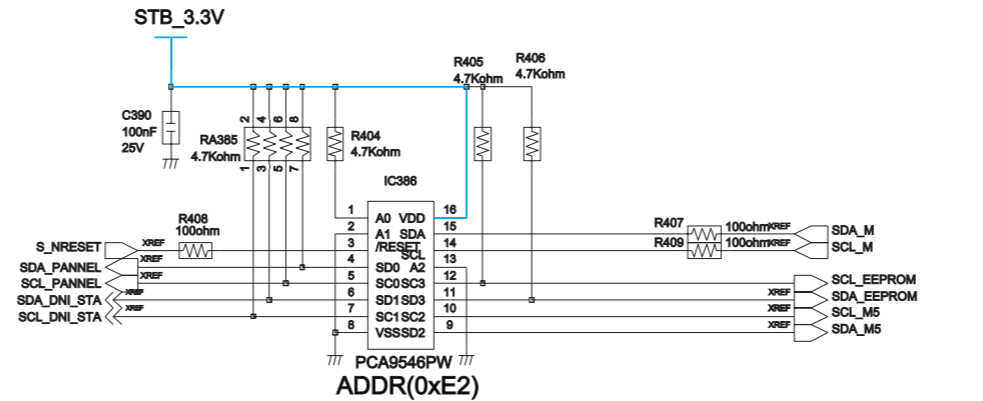
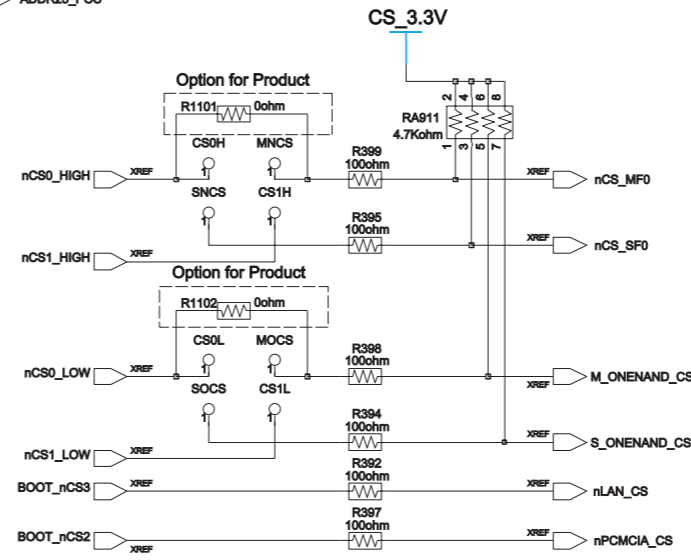
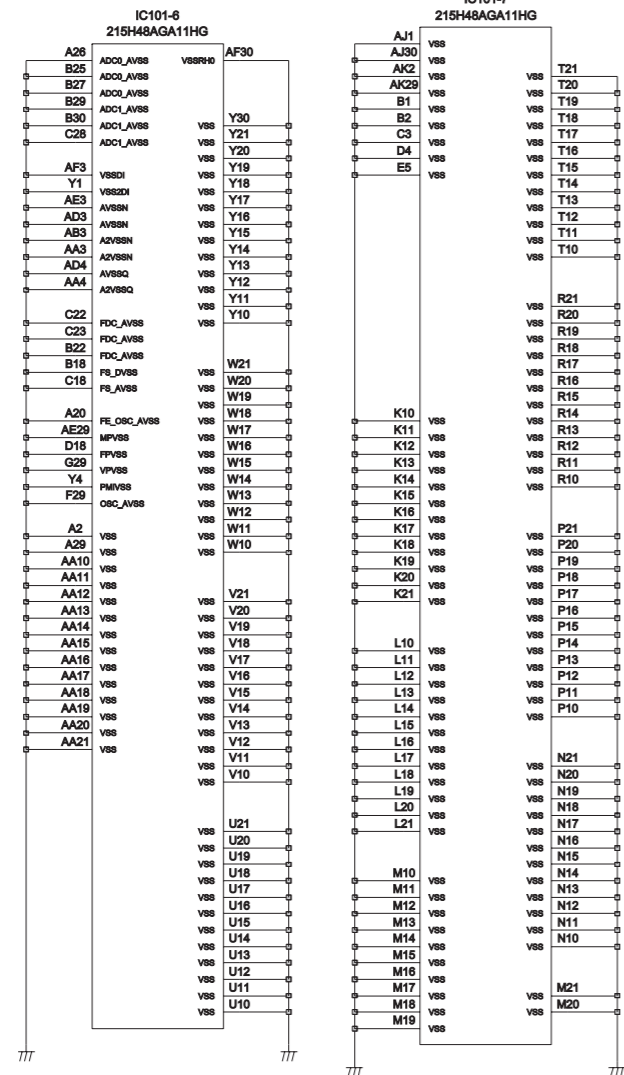
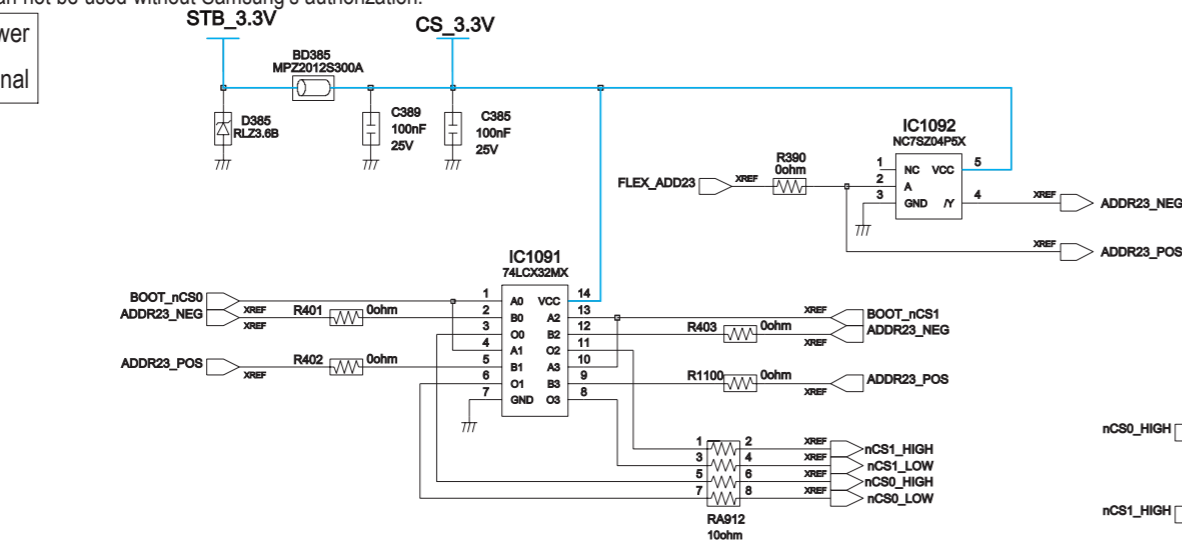
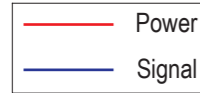

LAN CARD MODULE CONNECTOR

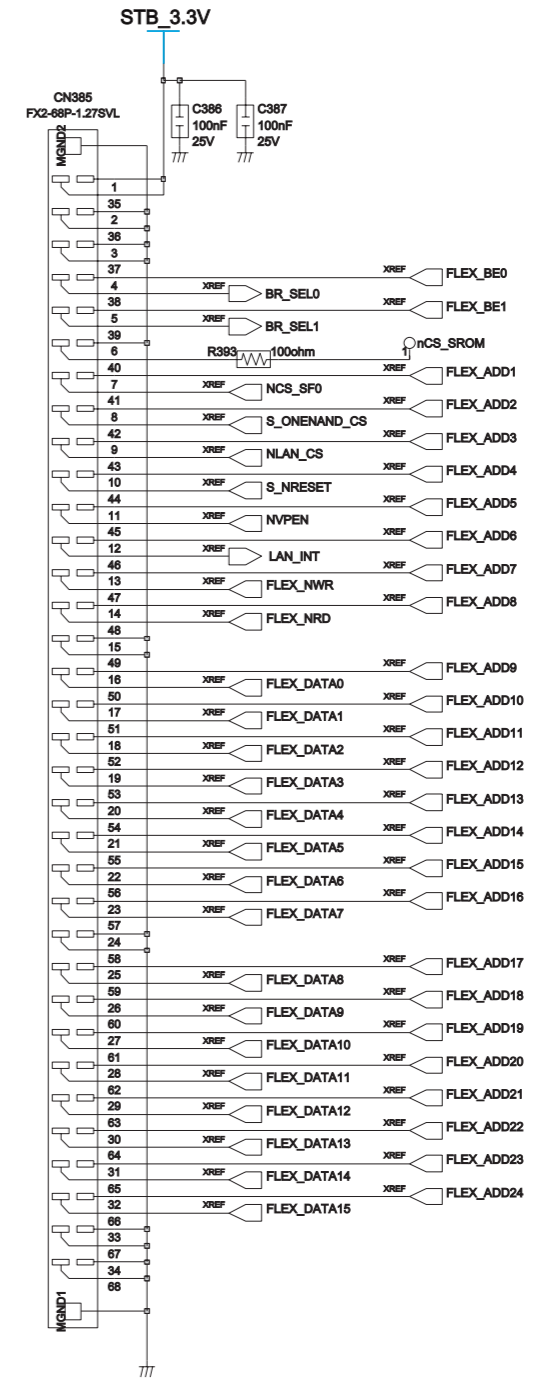

10-1-17 Main-17

This Document can not be used without Samsung's authorization.

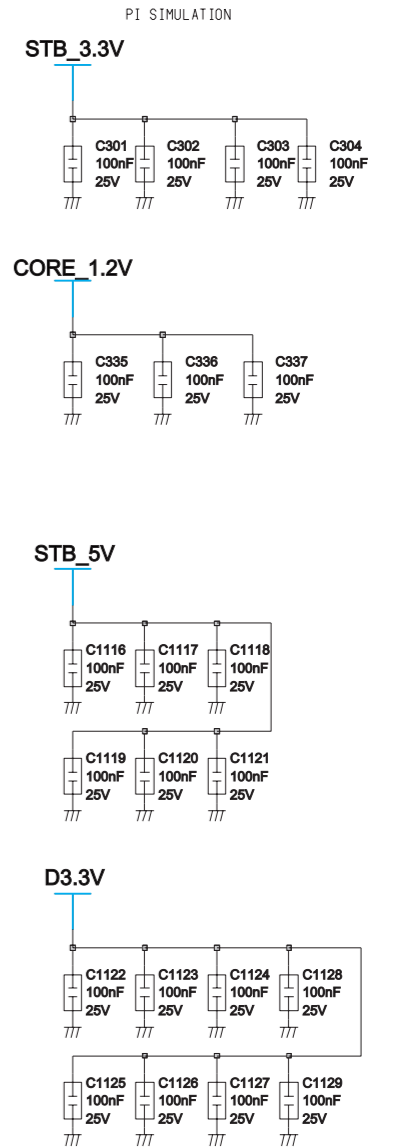
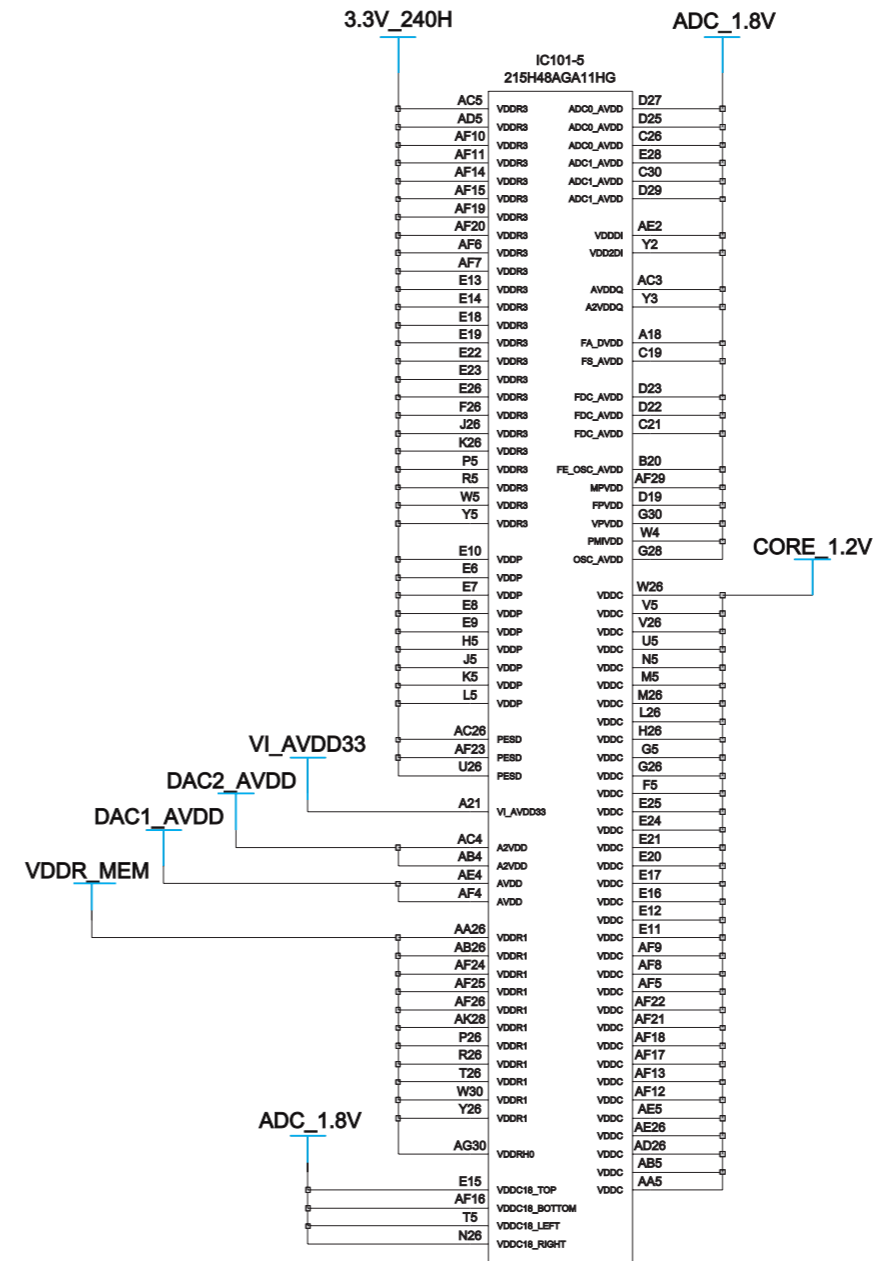
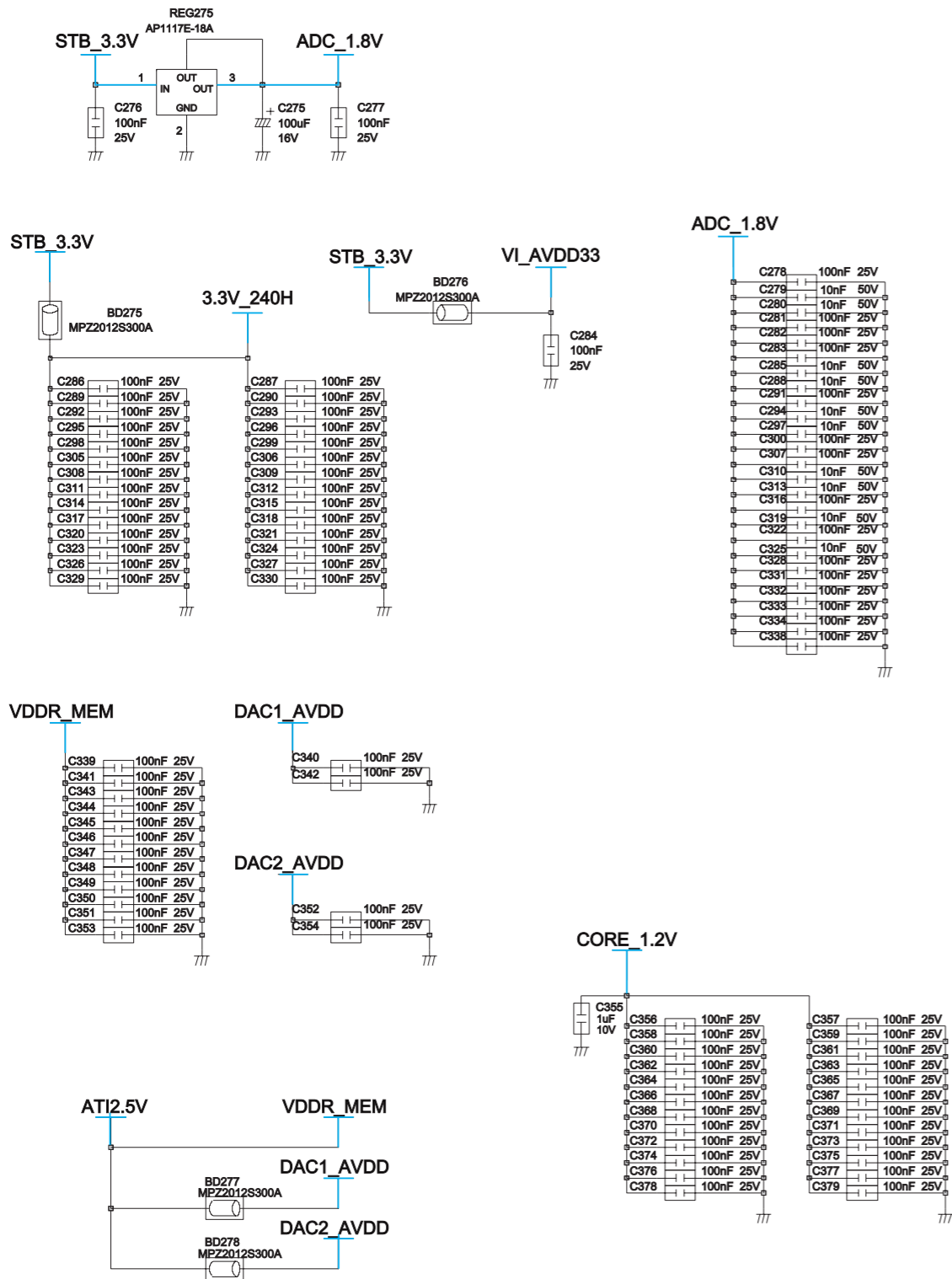
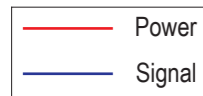

10-1-18 Main-18

This Document can not be used without Samsung's authorization.

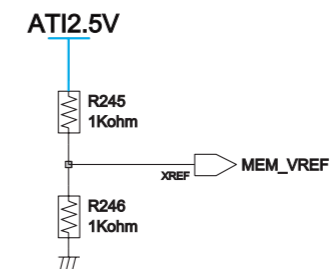
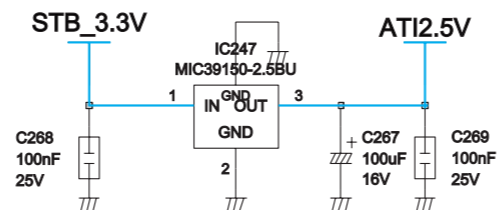
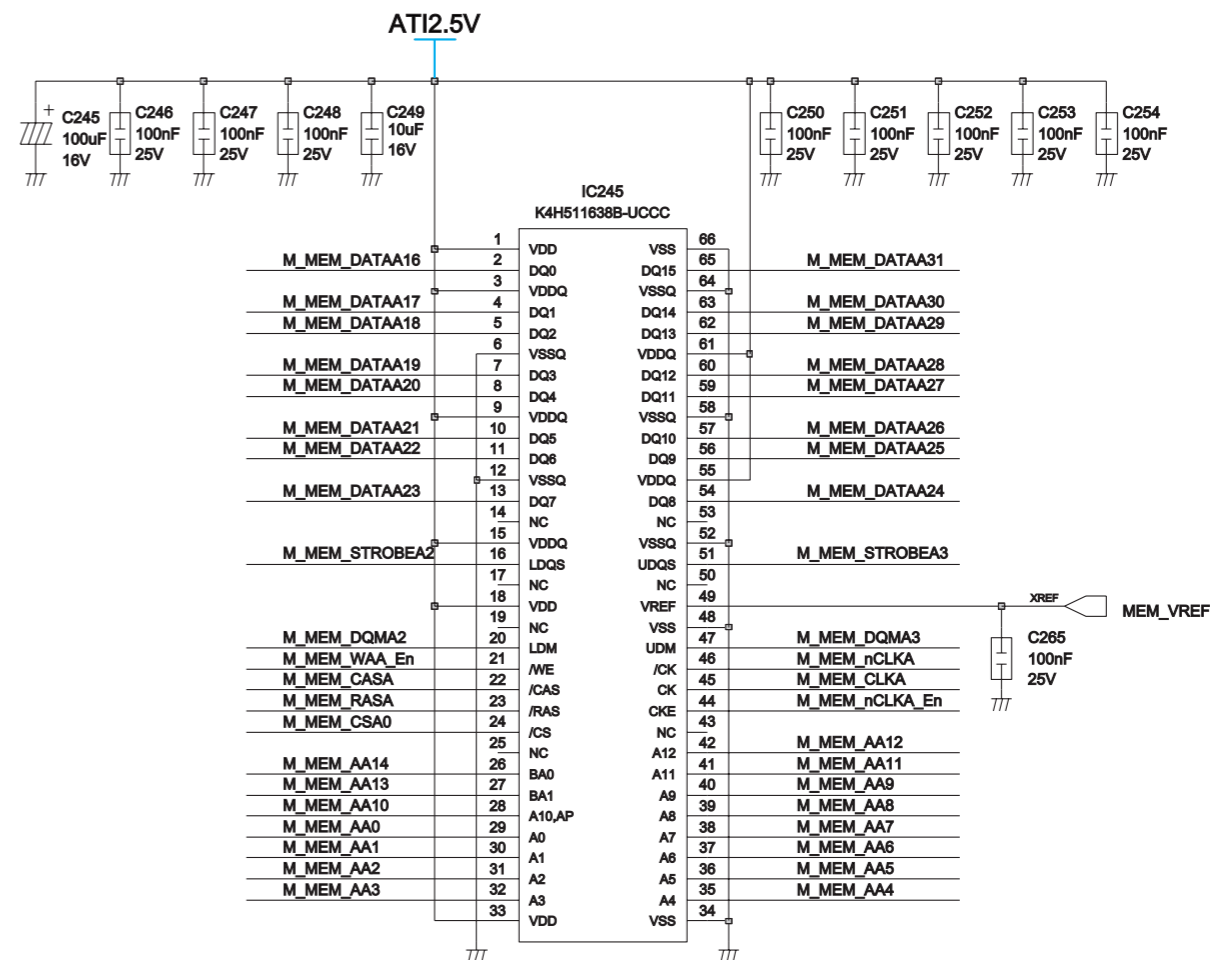
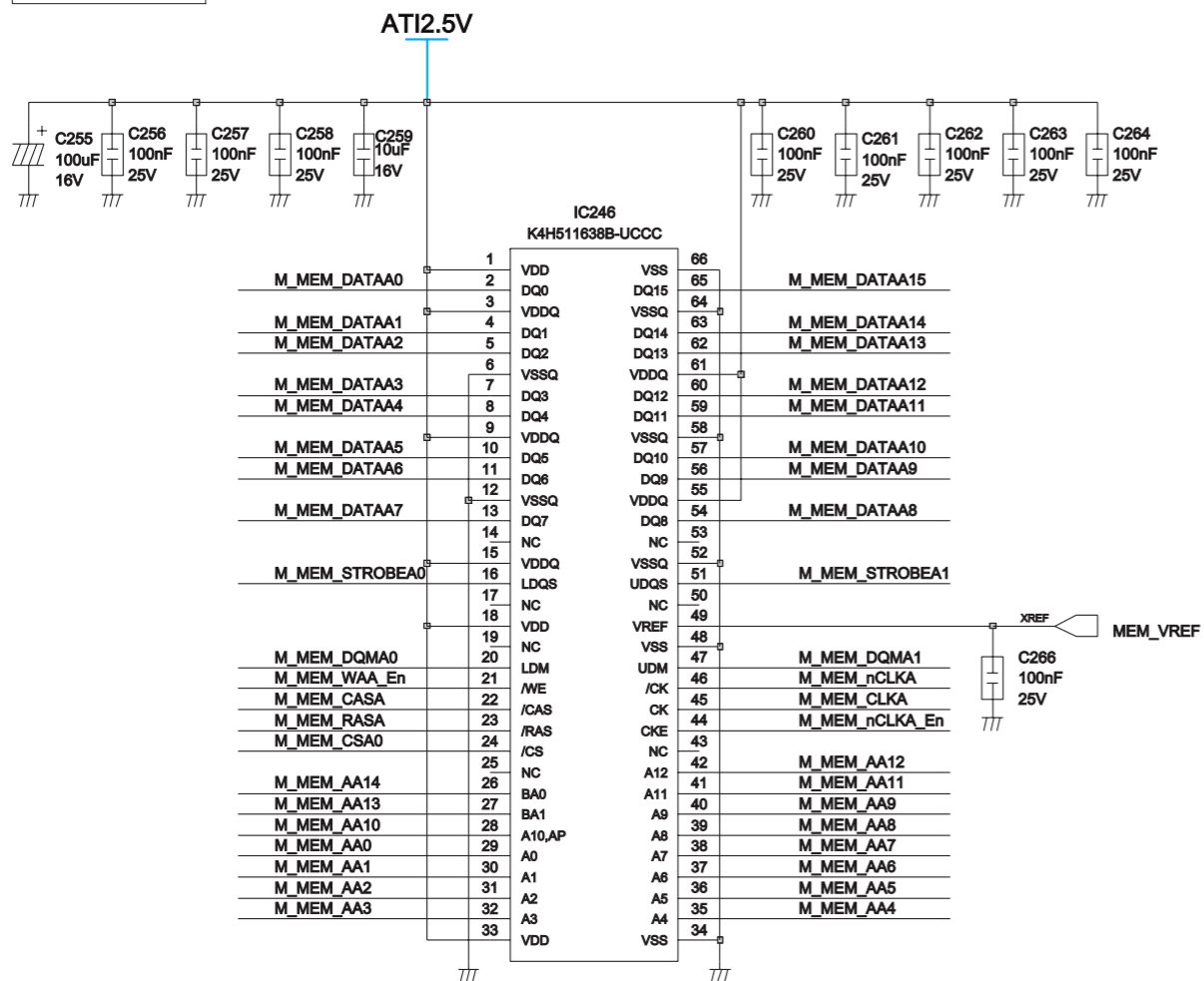
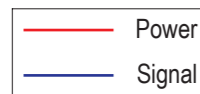

10-1-20 Main-20

This Document can not be used without Samsung's authorization.

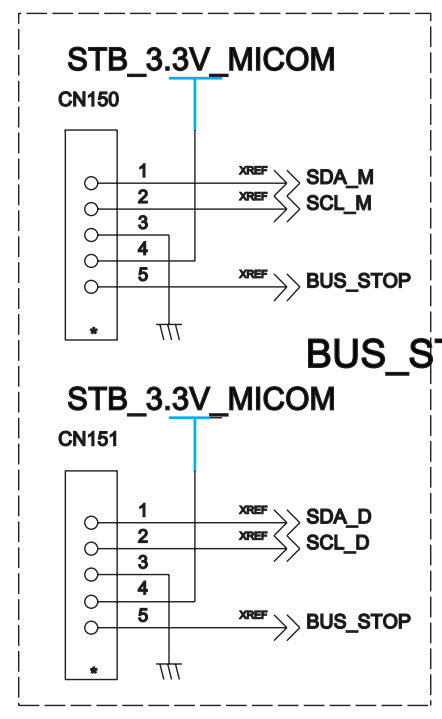
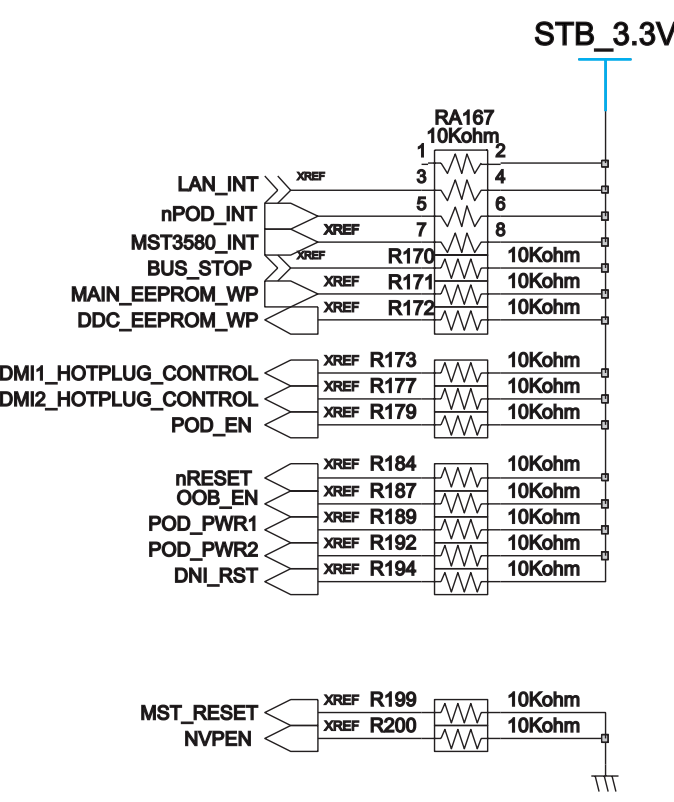
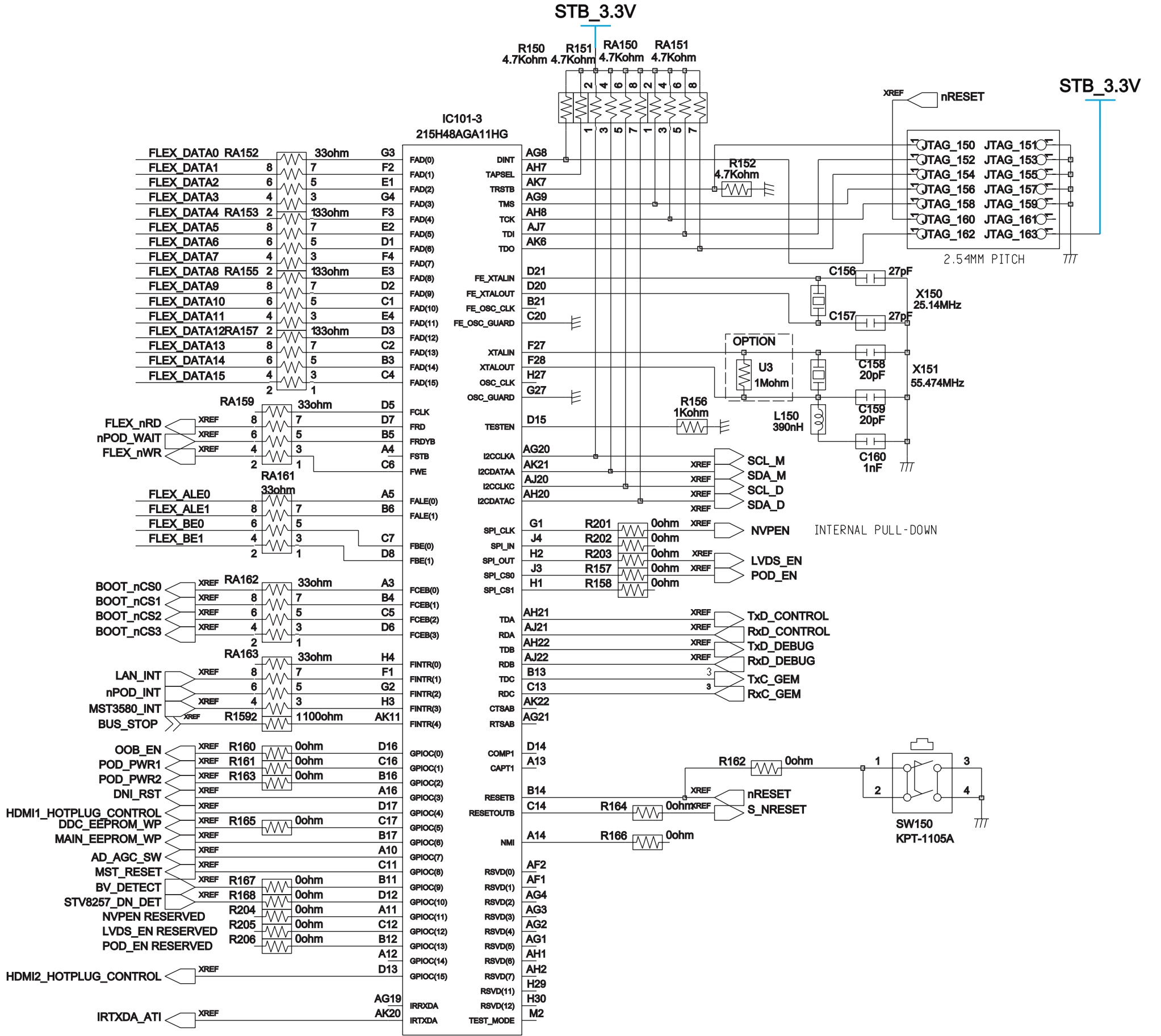
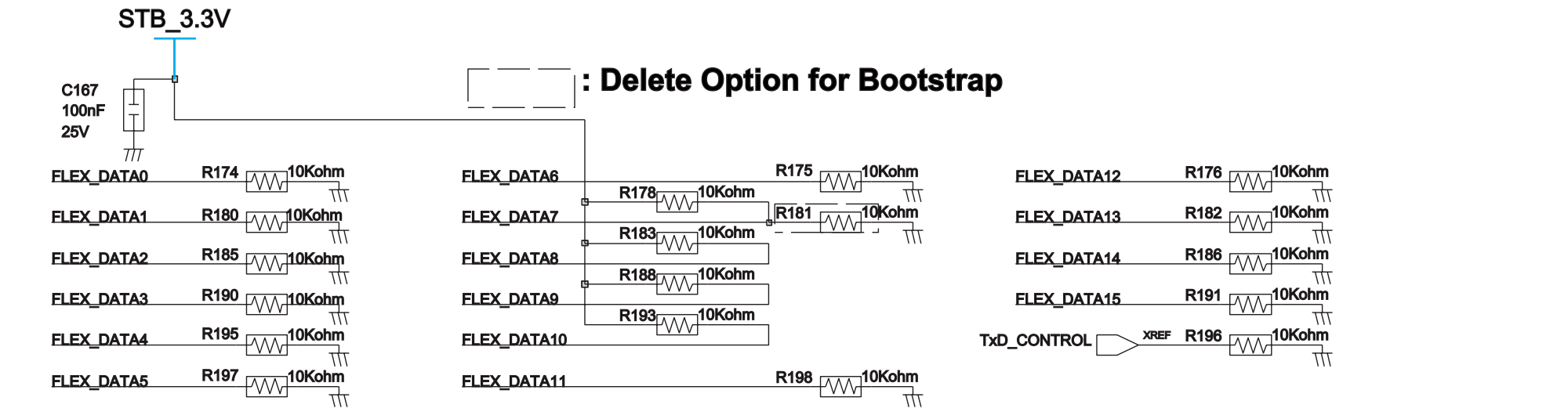
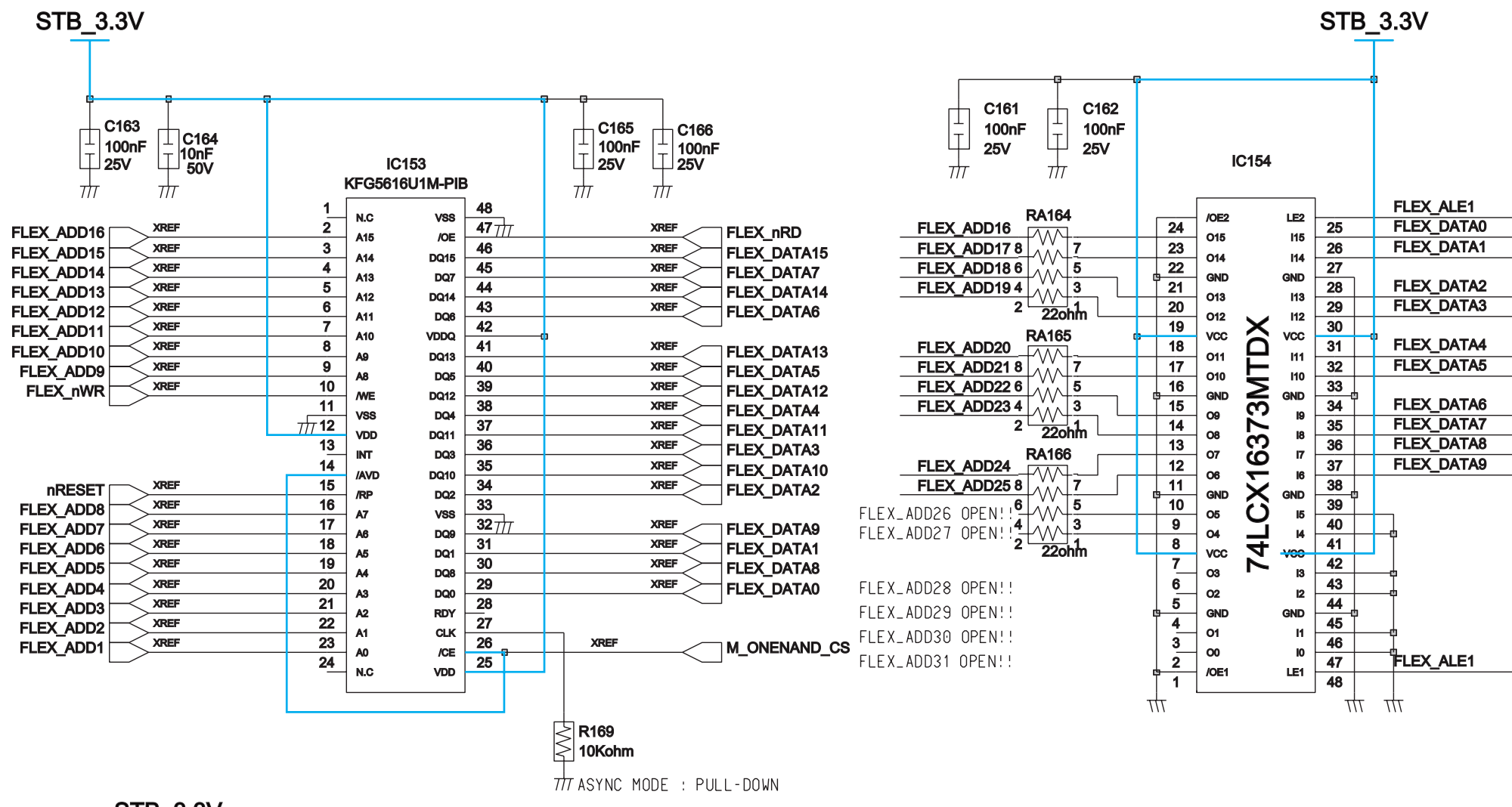
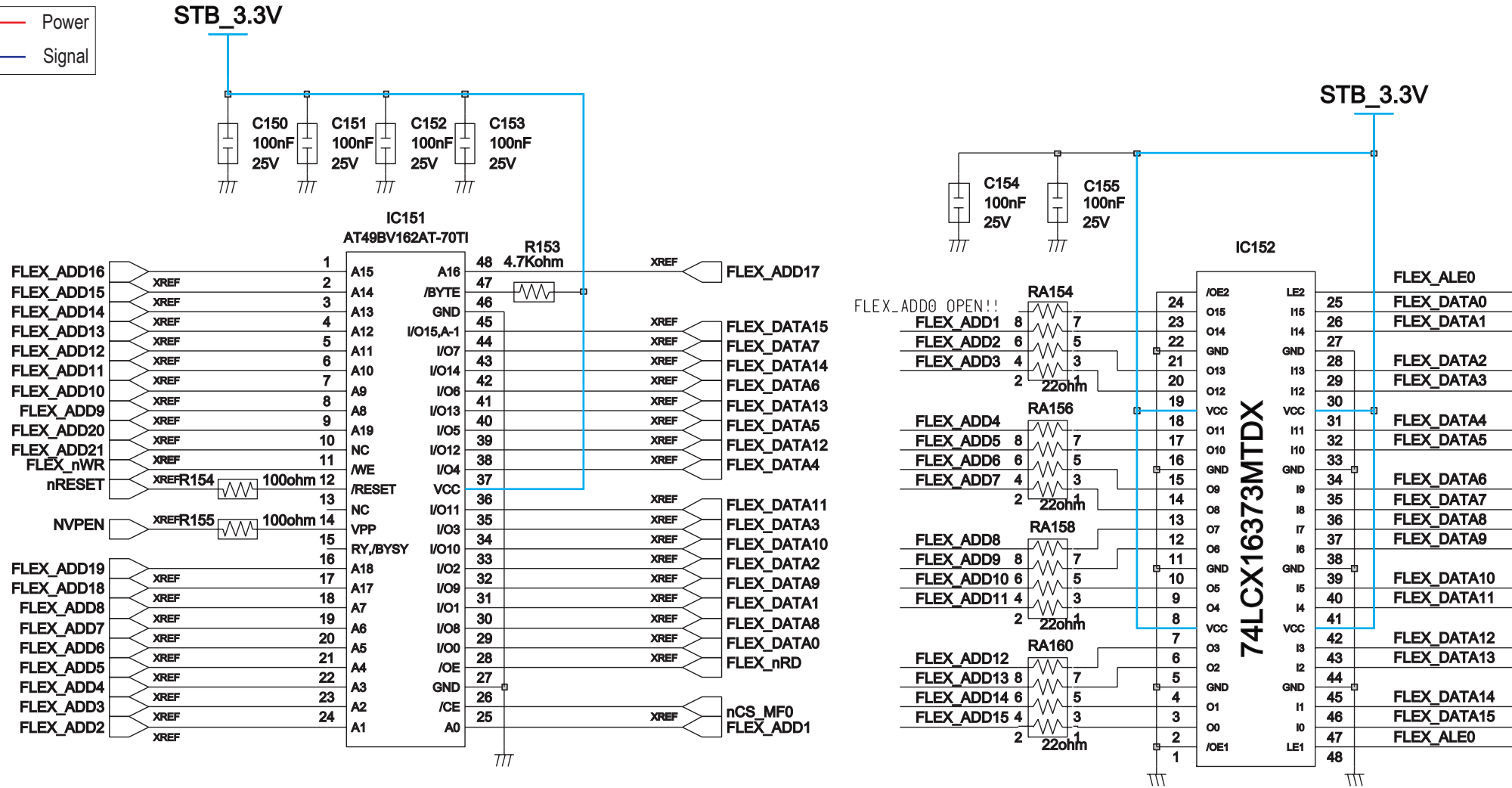
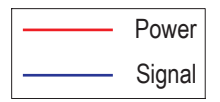

BUS_STOP for Debug

10-2 DMD Board

10-2-1 DMD Board-1

This Document can not be used without Samsung's authorization.

INPUT

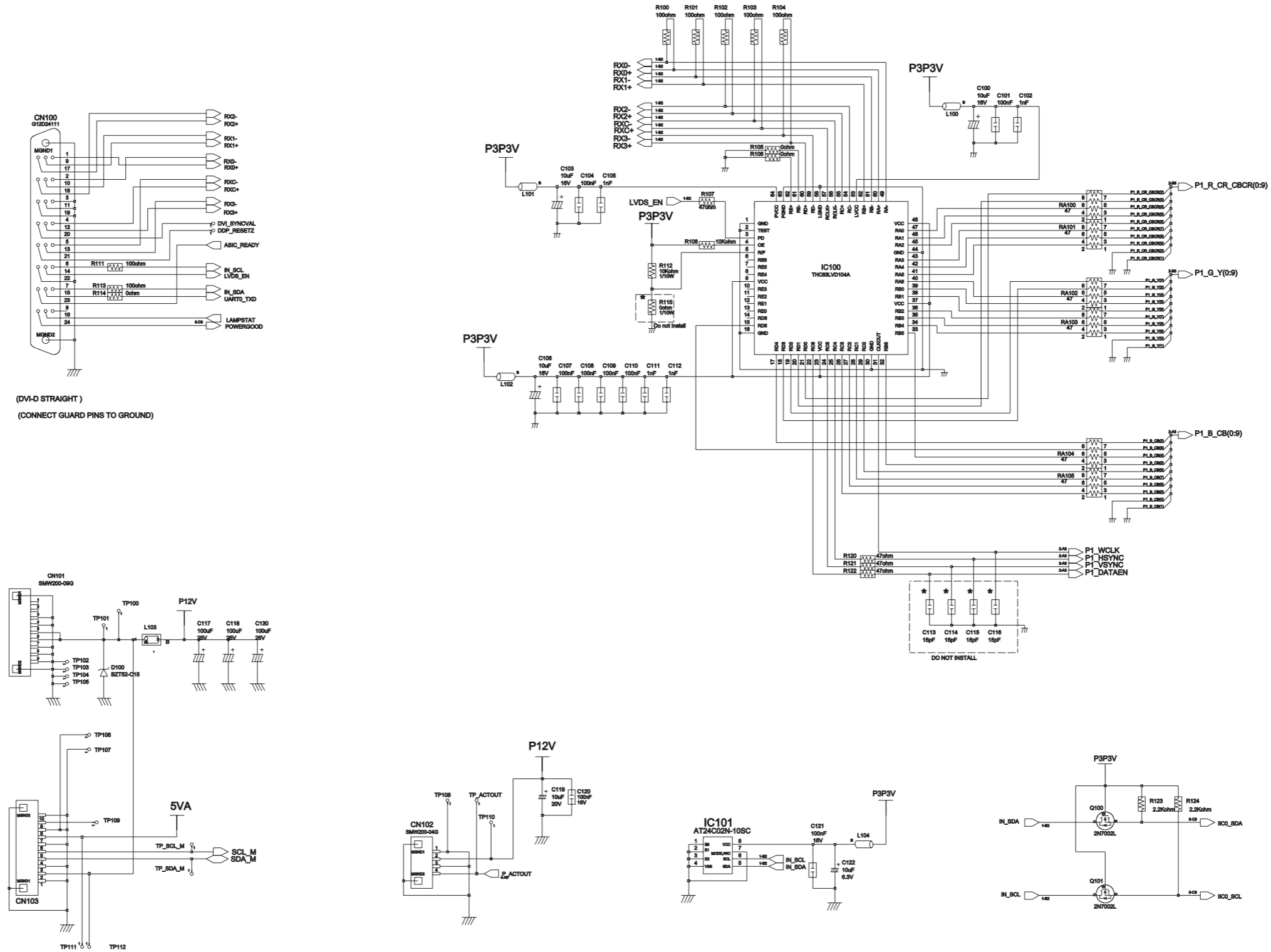

10-2-2 DMD Board-2

This Document can not be used without Samsung's authorization.

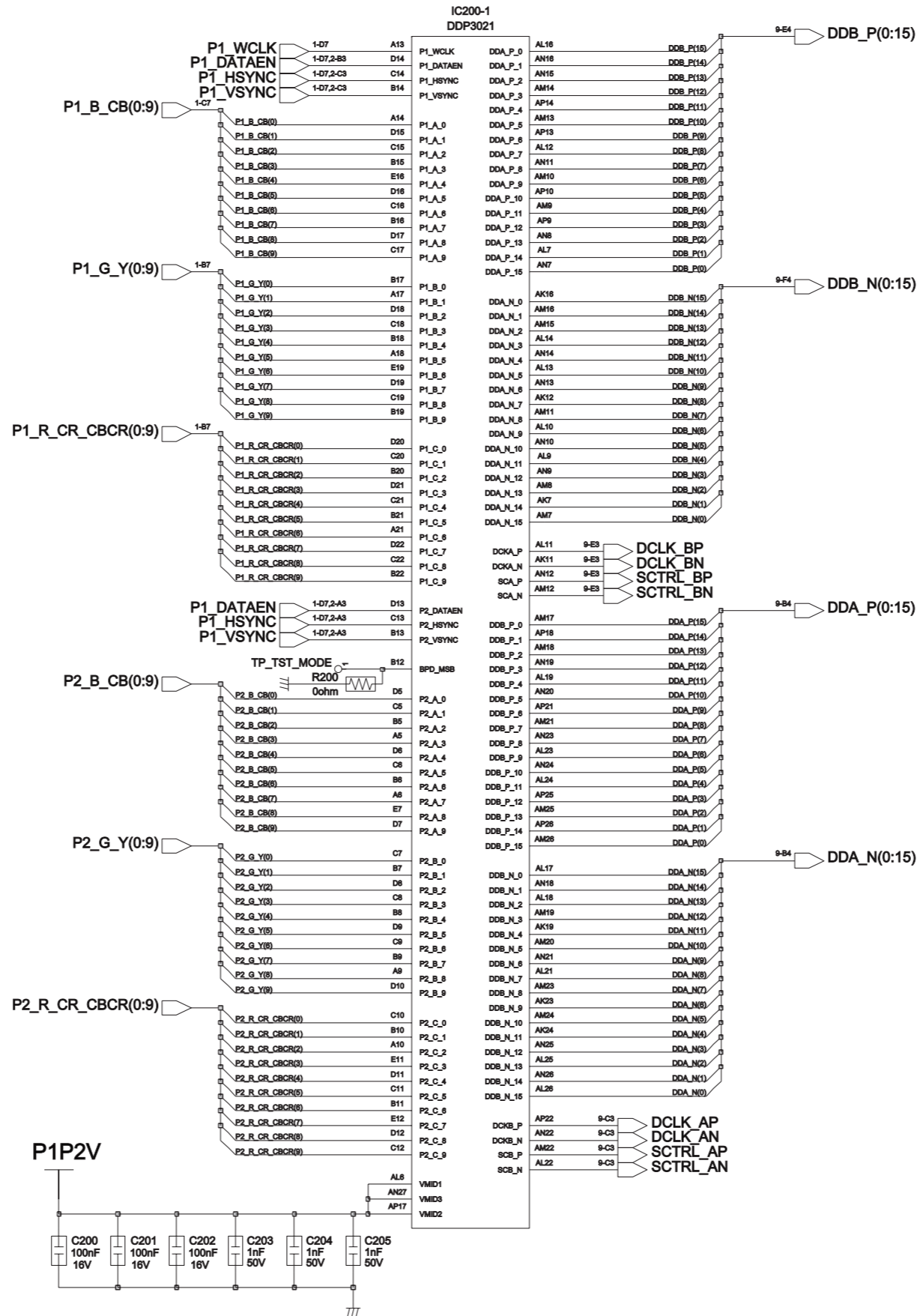

10-2-3 DMD Board-3

This Document can not be used without Samsung's authorization.

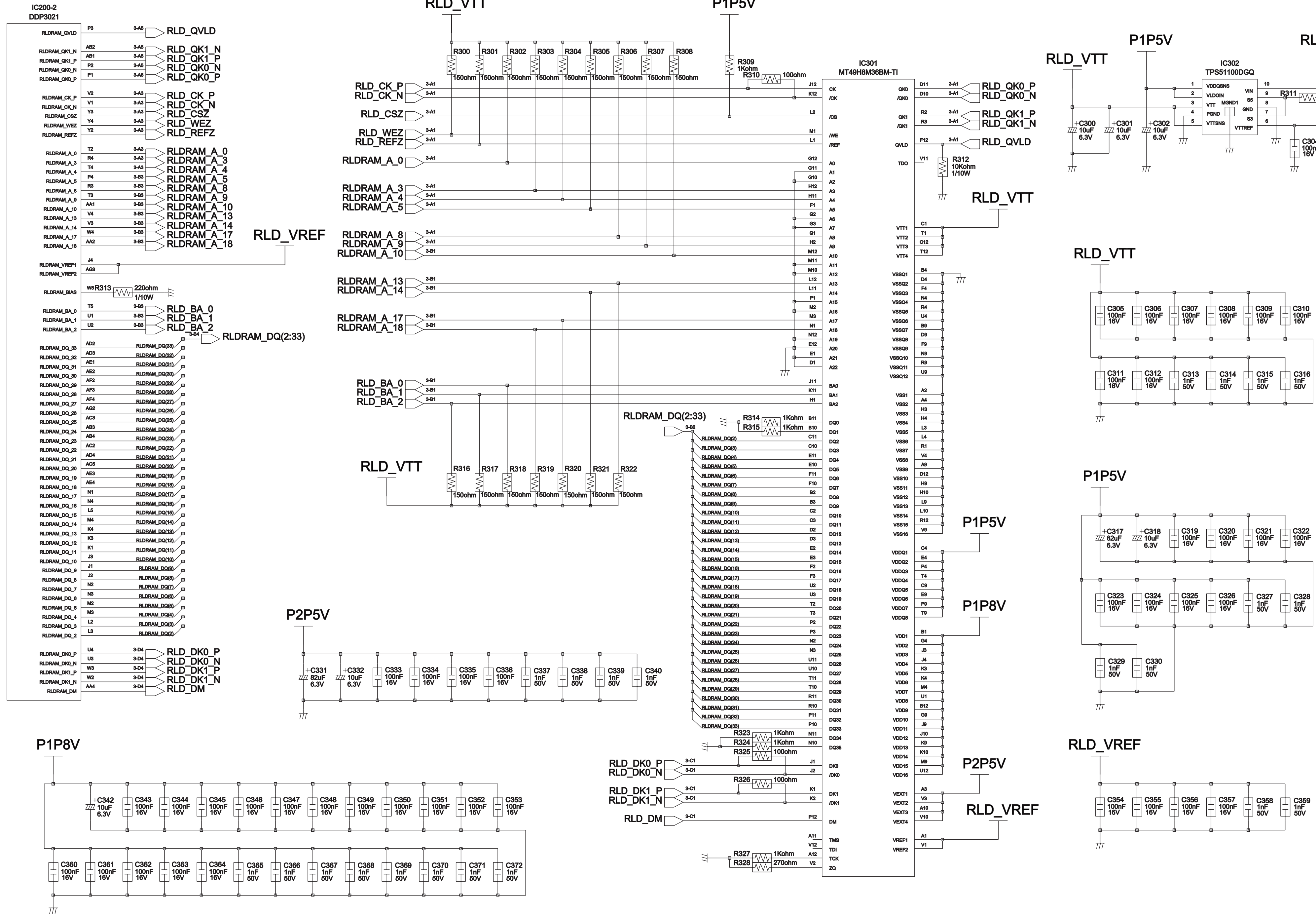

10-2-5 DMD Board-5

This Document can not be used without Samsung's authorization.

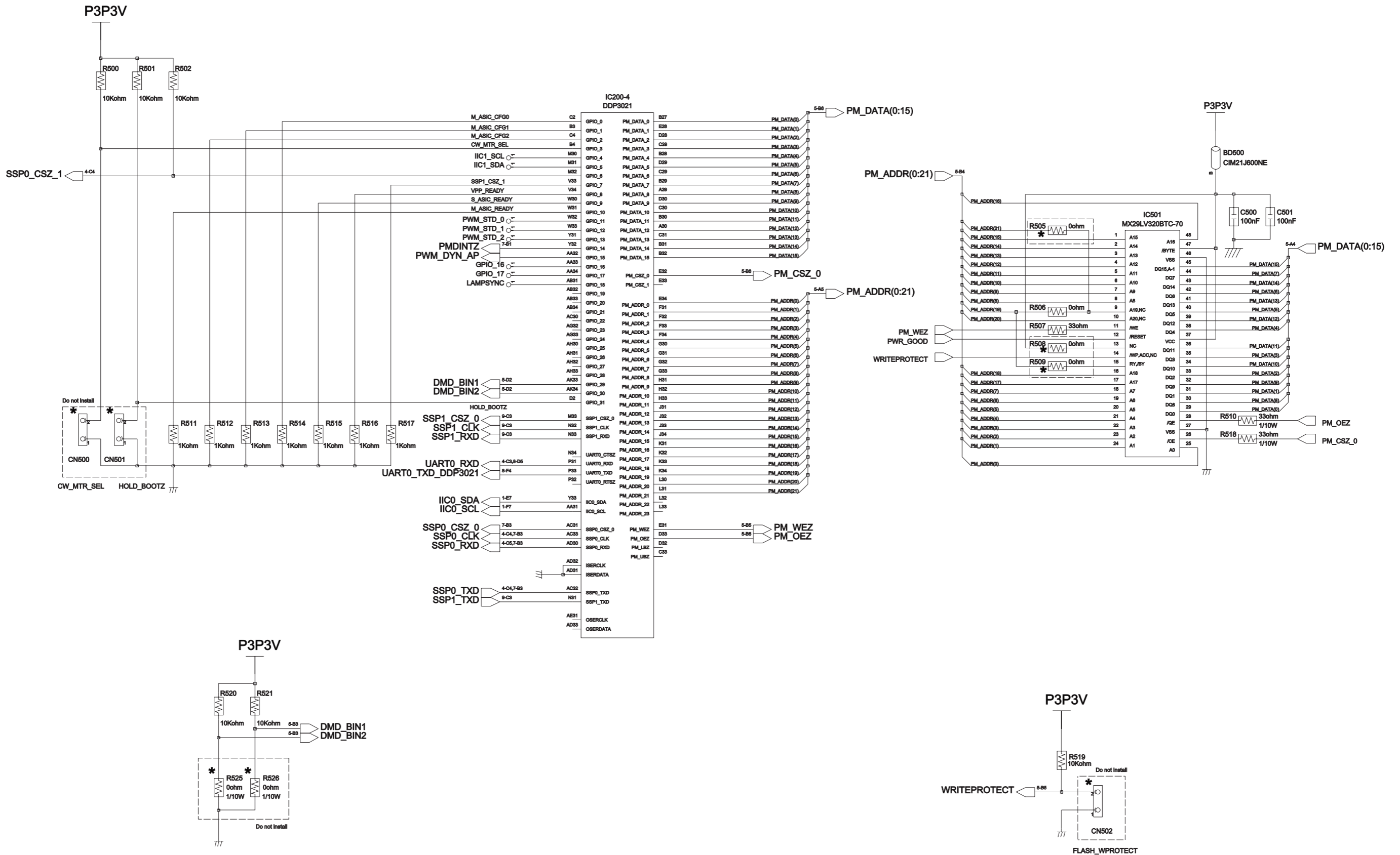

10-2-7 DMD Board-7

This Document can not be used without Samsung's authorization.

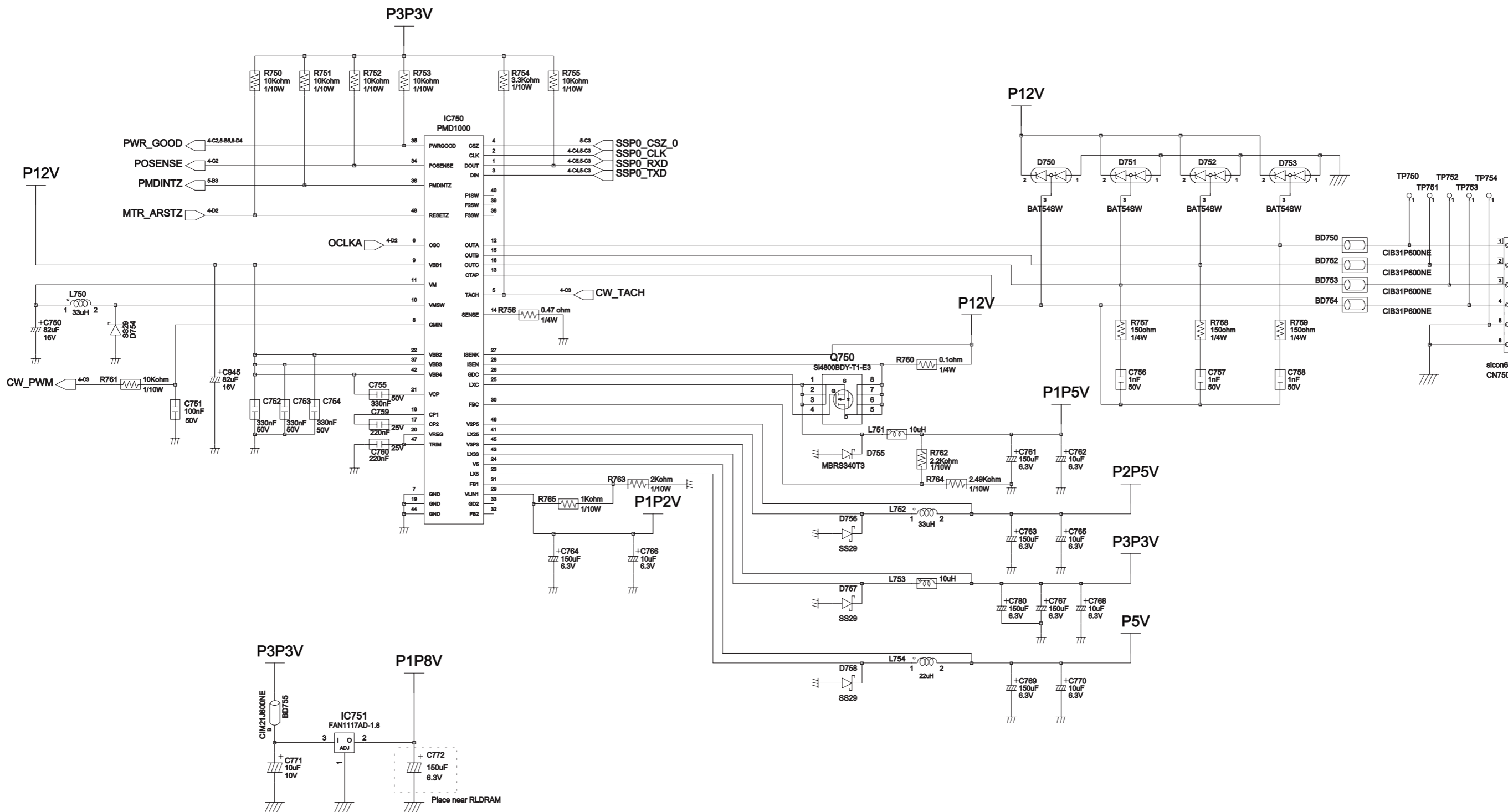

10-2-8 DMD Board-8

This Document can not be used without Samsung's authorization.

COLOR WHEEL SENSOR DETECTION

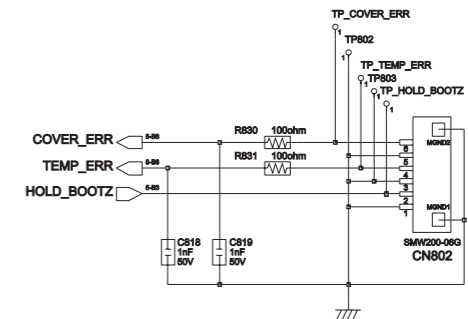
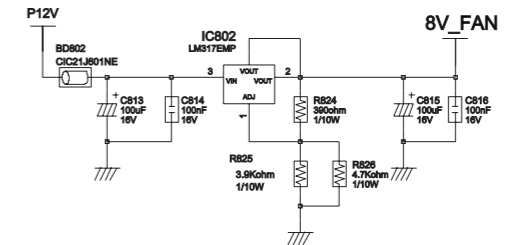
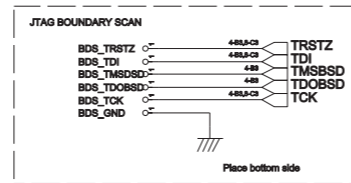
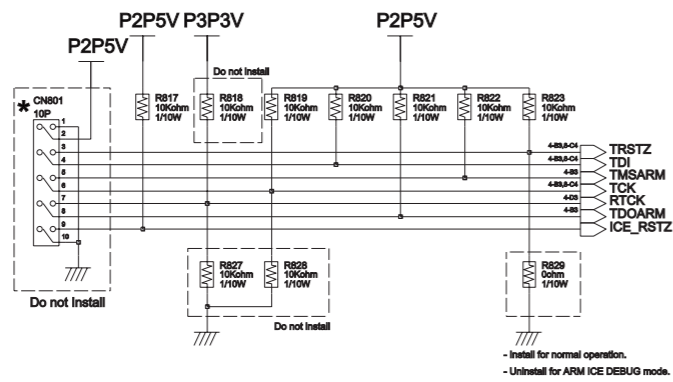
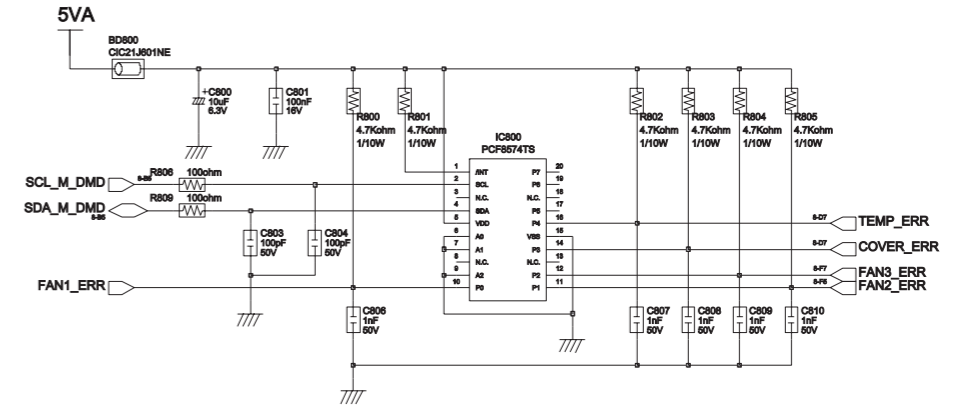
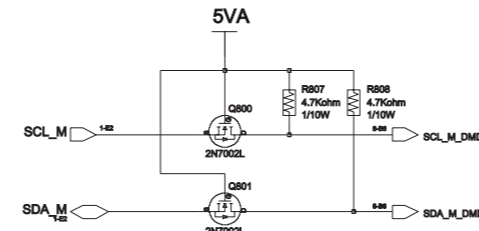
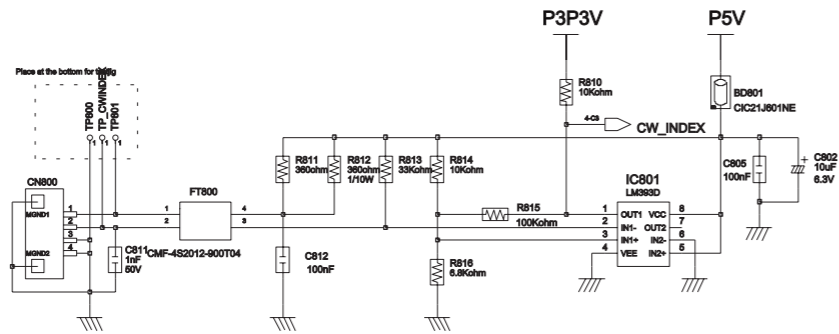

LAMP CONTROL

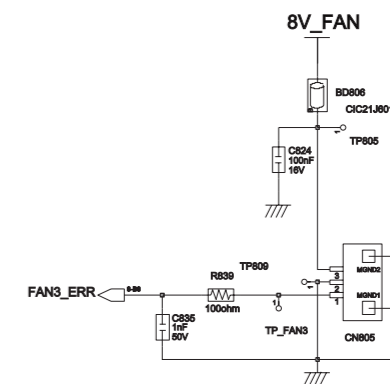
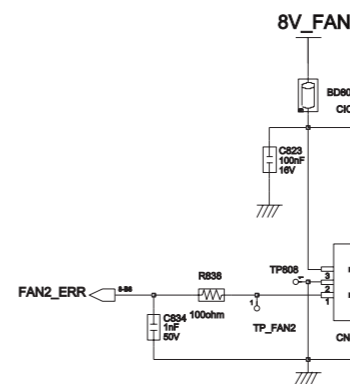
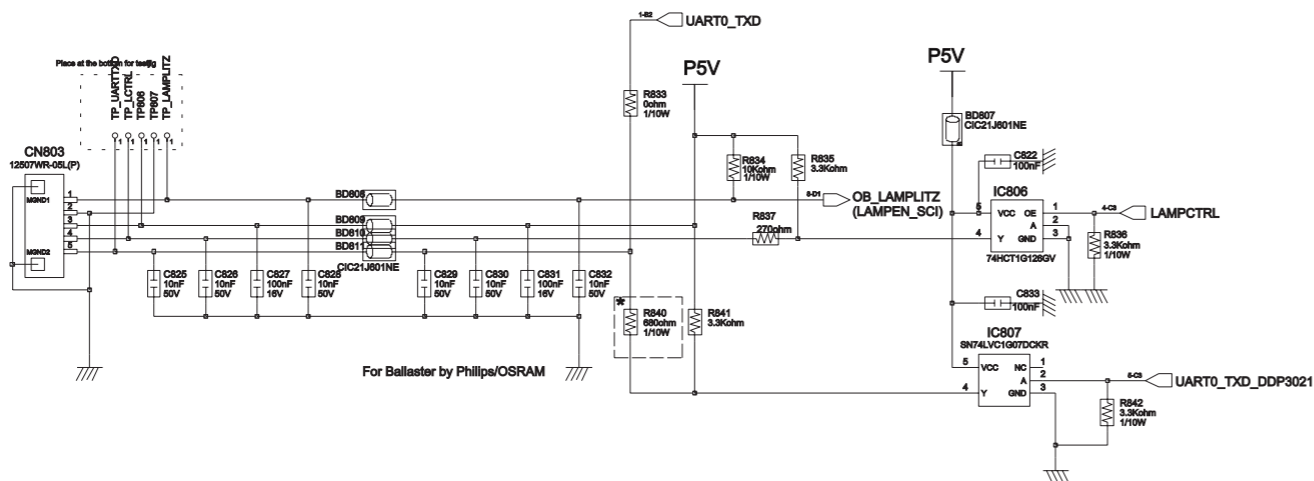
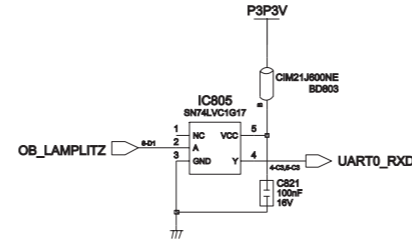
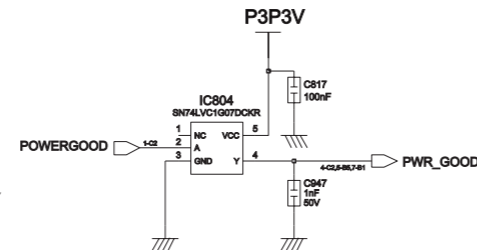
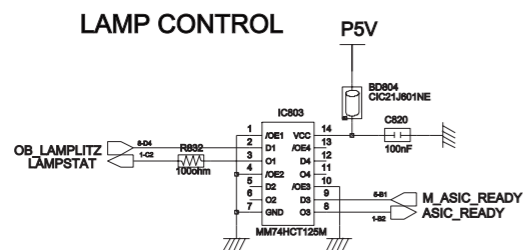

10-2-9 DMD Board-9

This Document can not be used without Samsung's authorization. (POWER PLANE)

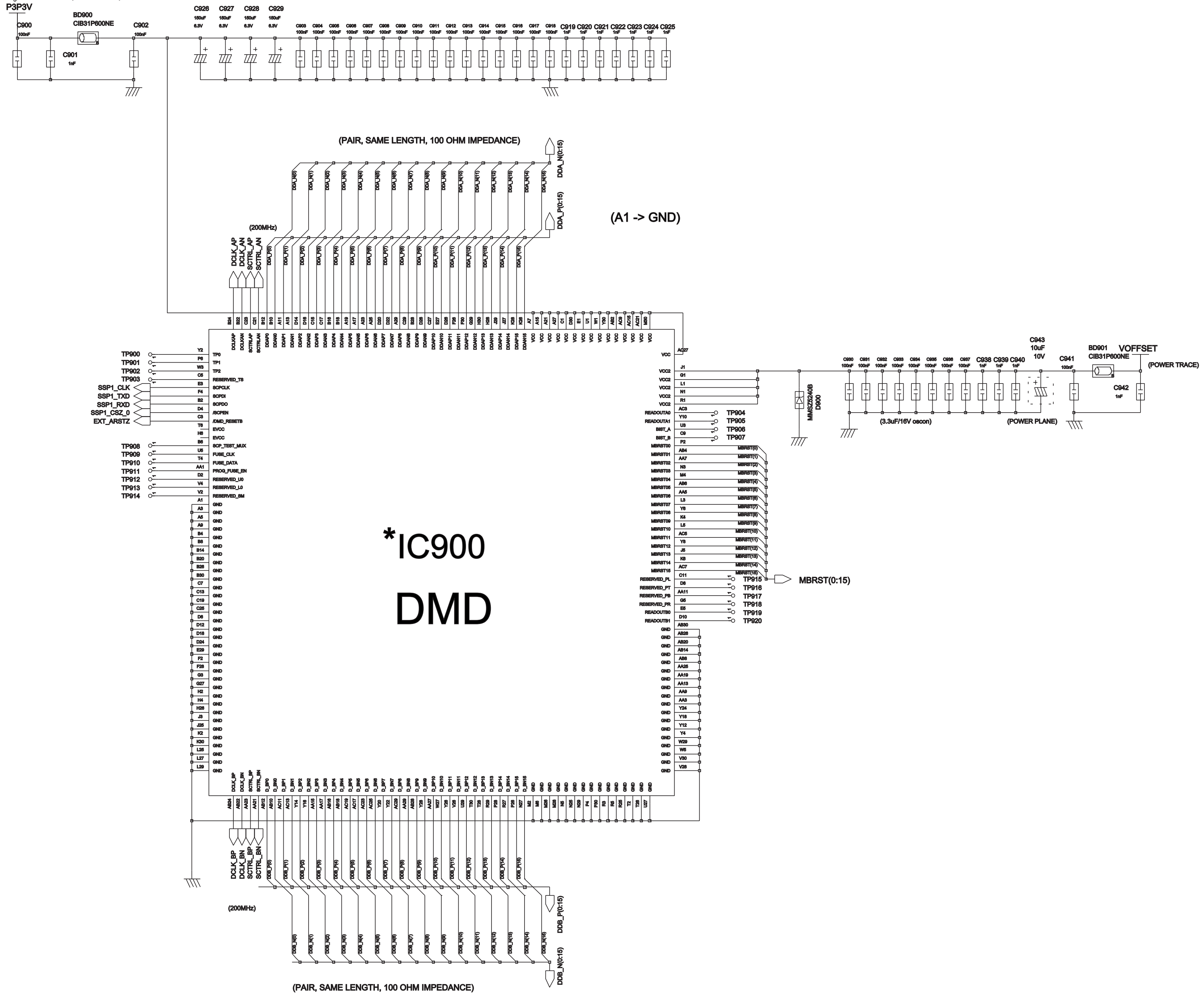

***IC900
DMD**

10-3 Power Board

This Document can not be used without Samsung's authorization.

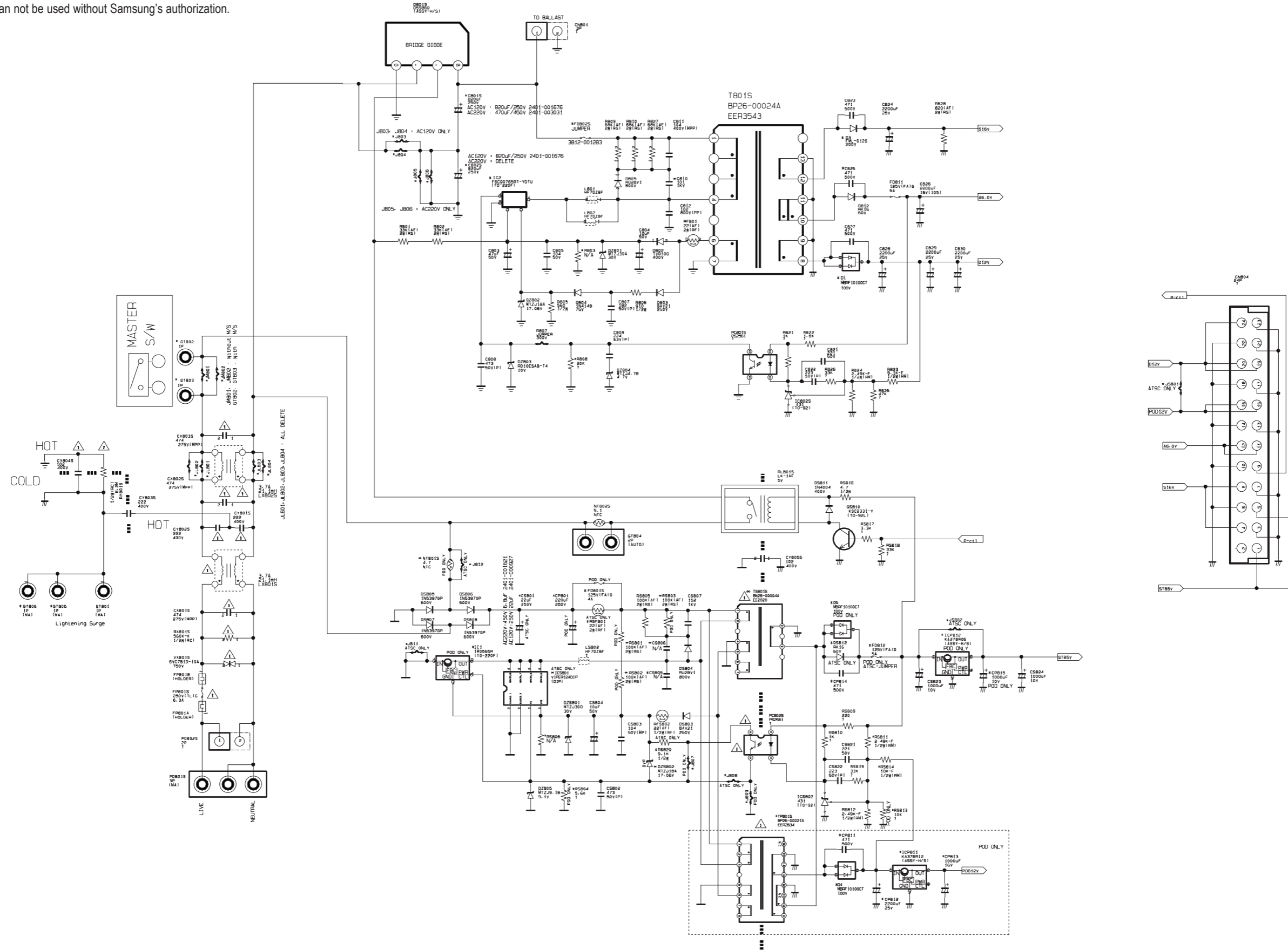

10-4 Key Control (L6)

This Document can not be used without Samsung's authorization.

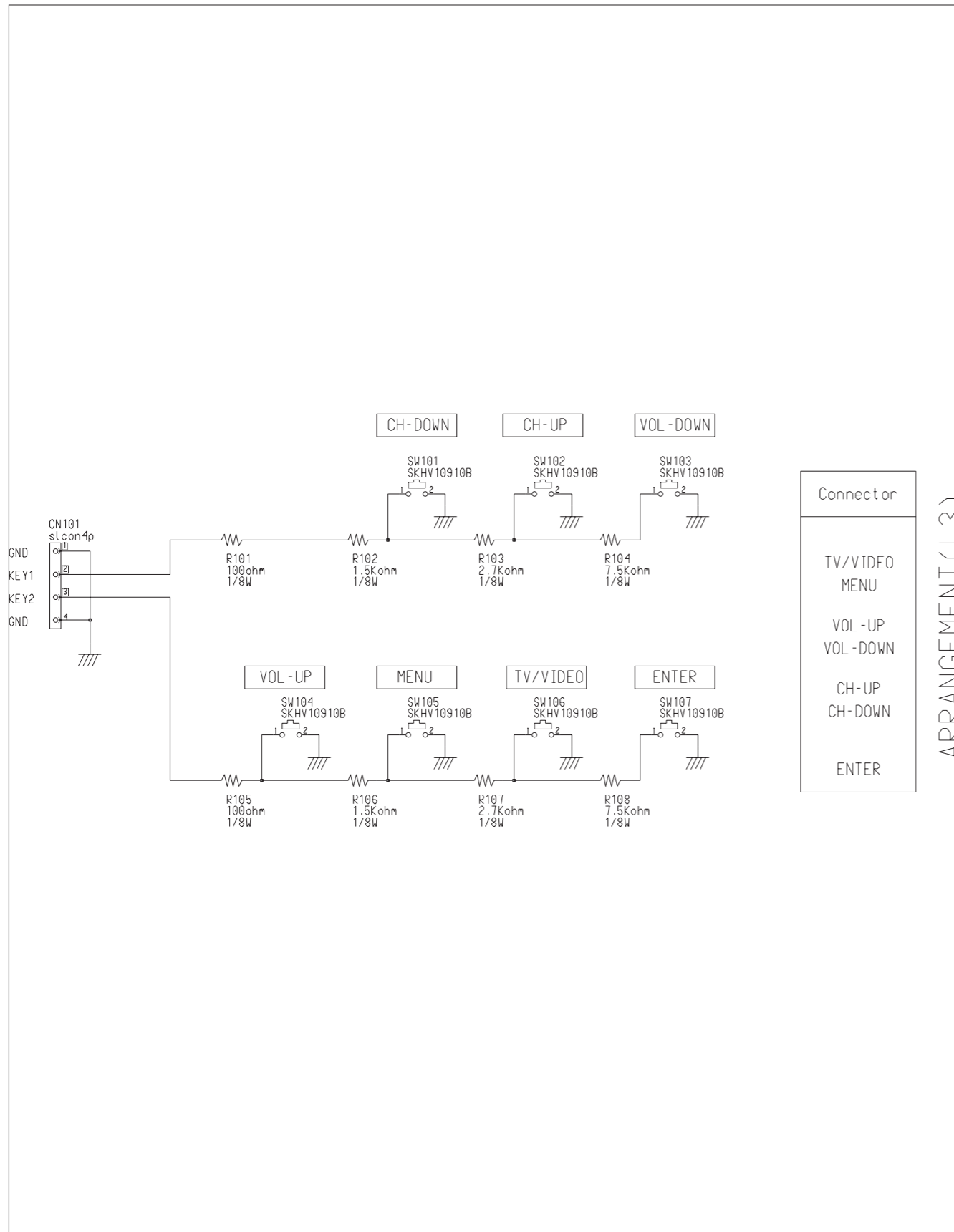

10-4 Key Control (K2)

This Document can not be used without Samsung's authorization.

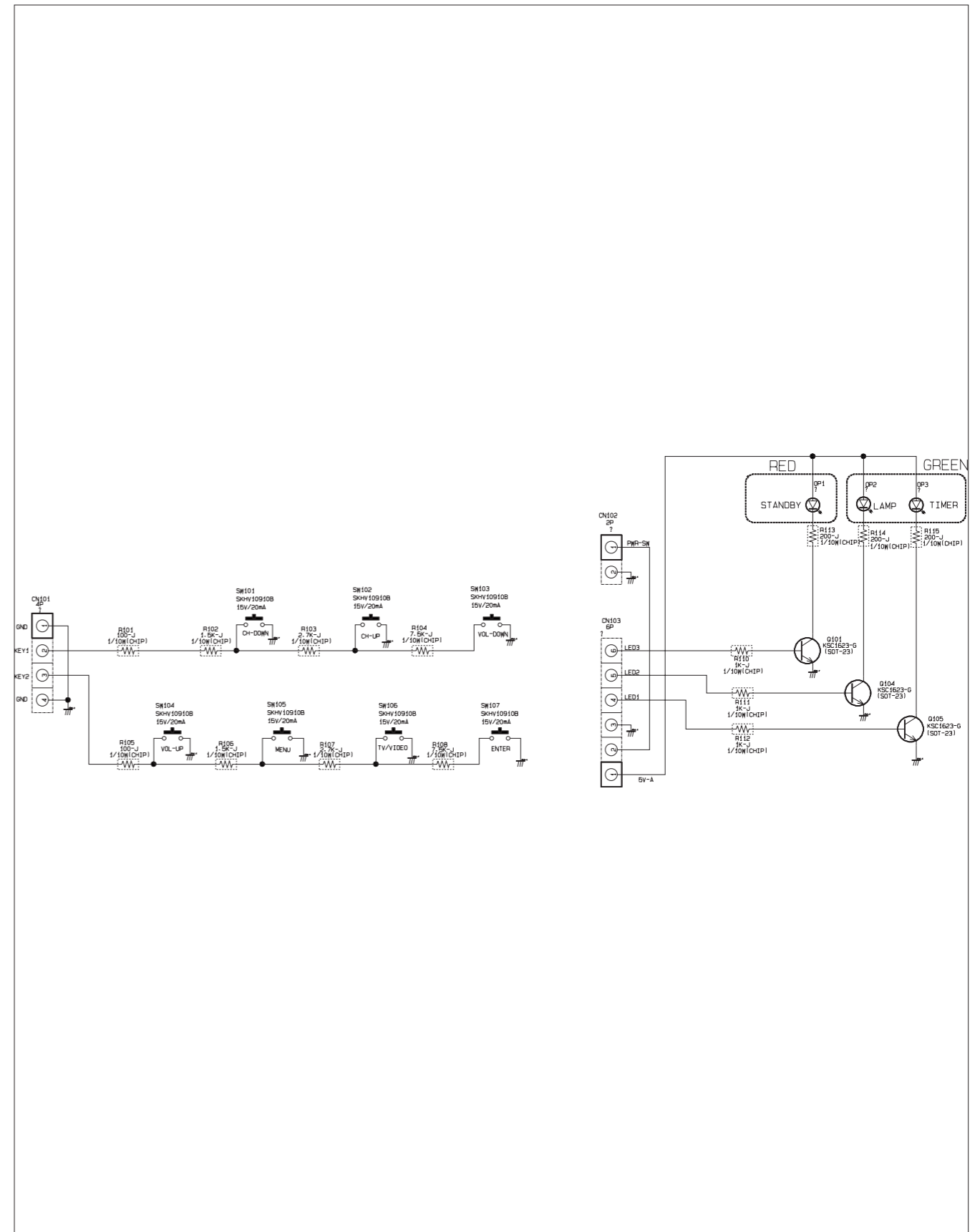

10-5 Side-AV (L6)

This Document can not be used without Samsung's authorization.

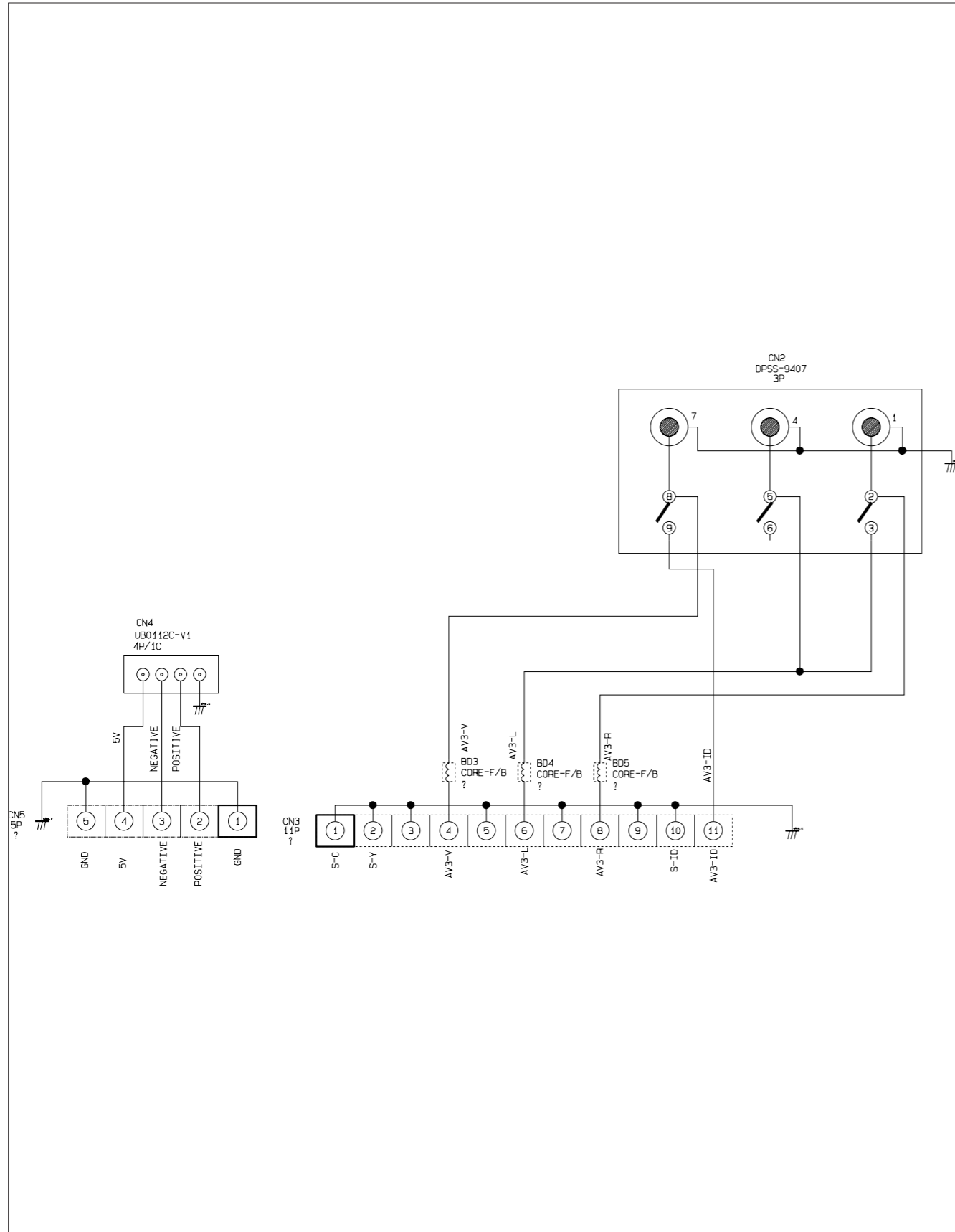

10-5 Side-AV (K2)

This Document can not be used without Samsung's authorization.

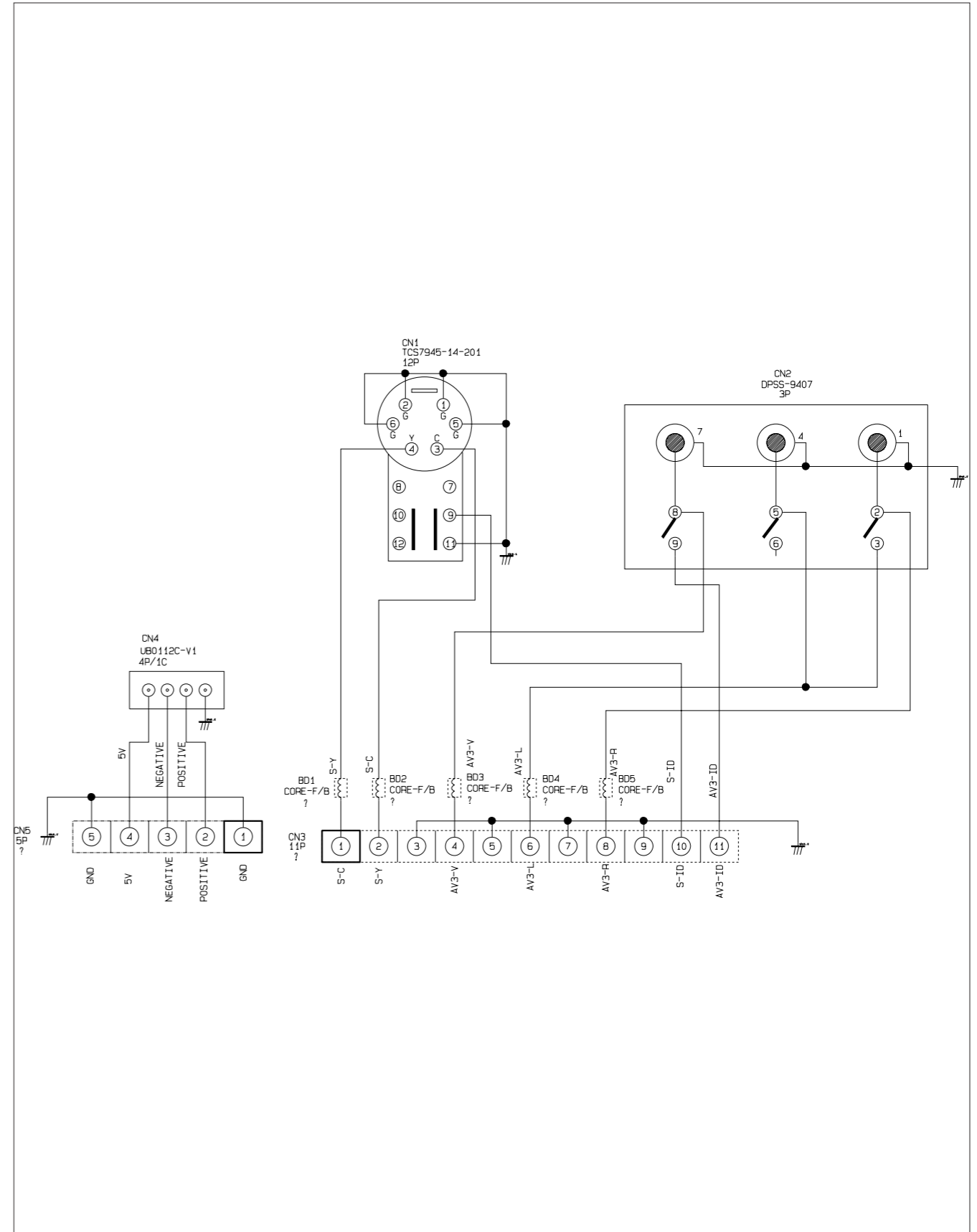

10-6 RMC LED (L6)

This Document can not be used without Samsung's authorization.

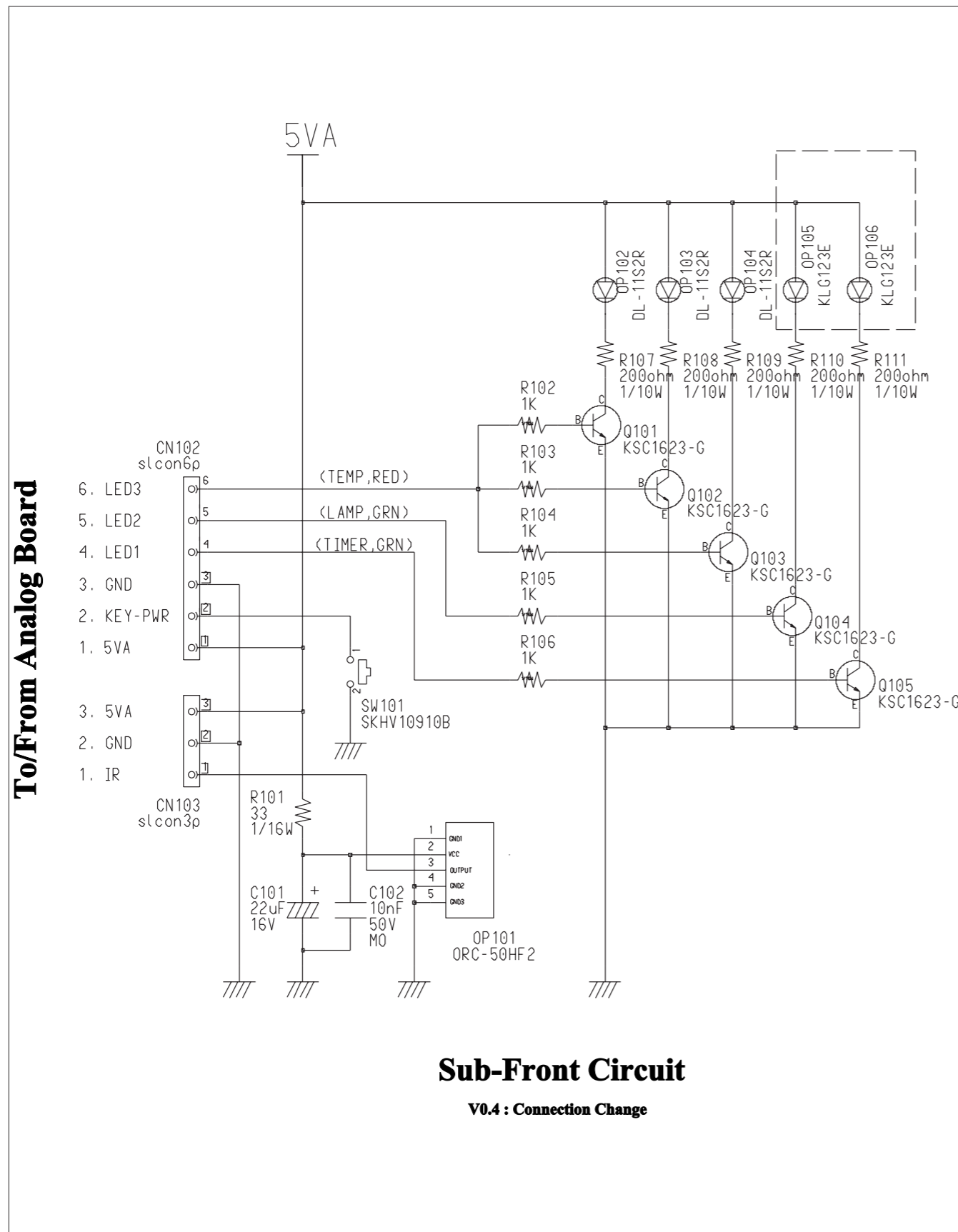

10-6 RMC (K2)

This Document can not be used without Samsung's authorization.

